

MANUAL

INSTALLATION | OPERATION | MAINTENANCE

DIGITAL VALVE POSITIONER **FY500**



HART[™]
COMMUNICATION PROTOCOL

MAR/24 - VERSION 1

smar
Technology Company

FY500

Digital Valve Positioner

Consult our
subsidiary



Rua Dr. Antônio Furlan Junior, 1028 - Sertãozinho, SP - CEP: 14170-480
insales@smar.com.br | +55 (16) 3946-3599 | www.smar.com

© Copyright 2022, Nova Smar S/A. All rights reserved. August 2022.
Specifications and information are subject to change.
Updated addresses are available on our website.

smar
Technology Company



GENERAL

This operation and maintenance instruction manual provides installation, operating, calibration, and maintenance information for the FY500.

The FY500 must only be installed, operated, and maintained by qualified personnel with fully trained in field equipment installation.

For additional assistance or if there is any question concerning the instructions, contact SMAR.

Modifying this product, substituting non-factory parts, or using maintenance procedures other than outlined could drastically affect performance and be hazardous to personnel and equipment, and may void existing warranties.

NOTE

This manual is compatible with version 1.XX, where 1 indicates software version and XX software release. The indication 1.XX means that this manual is compatible with any release of software version 1.

SAFETY TERMS

To avoid personal injury or property damage, WARNING and CAUTION notes must be strictly followed. Always follow the standard industry safety practices and cautions when working on this or any process control product.

Refer to the appropriate instruction for hazardous area.

WARNING

Throughout the operation of the positioner, including self setup, do not touch the moving parts of the valve/actuator/positioner set as they may unexpectedly move.

Do not remove FY500 from the valve while the valve is still pressurized. Make sure to disconnect the electric power, control signal, or air supply before touching any moving parts.

Check with the process or safety engineer for any additional measures that must be taken to protect the process.

UNPACKING AND STORAGE

Although Smar takes steps to prevent damage in transport, such damage is possible and must be discovered and reported before installing the FY500. Do not install the positioner that has been damaged in transport or during storage.

Waiver of responsibility

The contents of this manual abides by the hardware and software used on the current equipment version. Eventually there may occur divergencies between this manual and the equipment. The information from this document are periodically reviewed and the necessary or identified corrections will be included in the following editions. Suggestions for their improvement are welcome.

Warning

For more objectivity and clarity, this manual does not contain all the detailed information on the product and, in addition, it does not cover every possible mounting, operation or maintenance cases.

Before installing and utilizing the equipment, check if the model of the acquired equipment complies with the technical requirements for the application. This checking is the user's responsibility.

If the user needs more information, or on the event of specific problems not specified or treated in this manual, the information should be sought from Smar. Furthermore, the user recognizes that the contents of this manual by no means modify past or present agreements, confirmation or judicial relationship, in whole or in part.

All of Smar's obligation result from the purchasing agreement signed between the parties, which includes the complete and sole valid warranty term. Contractual clauses related to the warranty are not limited nor extended by virtue of the technical information contained in this manual.

Only qualified personnel are allowed to participate in the activities of mounting, electrical connection, startup and maintenance of the equipment. Qualified personnel are understood to be the persons familiar with the mounting, electrical connection, startup and operation of the equipment or other similar apparatus that are technically fit for their work. Smar provides specific training to instruct and qualify such professionals. However, each country must comply with the local safety procedures, legal provisions and regulations for the mounting and operation of electrical installations, as well as with the laws and regulations on classified areas, such as intrinsic safety, explosion proof, increased safety and instrumented safety systems, among others.

The user is responsible for the incorrect or inadequate handling of equipments run with pneumatic or hydraulic pressure or, still, subject to corrosive, aggressive or combustible products, since their utilization may cause severe bodily harm and/or material damages.

The field equipment referred to in this manual, when acquired for classified or hazardous areas, has its certification void when having its parts replaced or interchanged without functional and approval tests by Smar or any of Smar authorized dealers, which are the competent companies for certifying that the equipment in its entirety meets the applicable standards and regulations. The same is true when converting the equipment of a communication protocol to another. In this case, it is necessary sending the equipment to Smar or any of its authorized dealer. Moreover, the certificates are different and the user is responsible for their correct use.

Always respect the instructions provided in the Manual. Smar is not responsible for any losses and/or damages resulting from the inadequate use of its equipments. It is the user's responsibility to know and apply the safety practices in his country.

TABLE OF CONTENTS

SECTION 1 - INSTALLATION	1.1
SAFETY INSTRUCTIONS	1.1
MOUNTING	1.1
QUARTER TURN ROTARY ACTUATORS	1.2
LINEAR ACTUATOR	1.7
PNEUMATIC CONNECTIONS	1.13
DIMENSIONAL DRAWINGS	1.15
ELECTRICAL WIRING	1.16
4 – 20 MA LOOP CONNECTIONS	1.16
TEST CONNECTIONS	1.17
COMMUNICATION CONNECTIONS	1.18
FEEDBACK CONNECTIONS	1.18
ELECTRONIC HOUSING ROTATION	1.19
CHANGING THE DISPLAY POSITION	1.20
SPLIT-RANGE OPERATION	1.22
INSTALLATION IN HAZARDOUS AREAS	1.23
EXPLOSION/FLAME PROOF	1.23
INTRINSICALLY SAFE	1.23
SECTION 2 - OPERATION	2.1
PRINCIPLE OF OPERATION	2.1
DISPLAY	2.2
SECTION 3 - TECHNICAL CHARACTERISTICS	3.1
FUNCTIONAL SPECIFICATIONS	3.1
PERFORMANCE SPECIFICATIONS	3.2
PHYSICAL SPECIFICATIONS	3.2
ORDERING CODE	3.3
SECTION 4 - LOCAL PROGRAMMING	4.1
LOCAL ADJUSTMENT	4.1
JUMPERS SELECTION	4.2
LOCAL PROGRAMMING TREE	4.3
CONFIGURABLE PARAMETERS	4.4
RESTORE FACTORY SETTINGS	4.6
SECTION 5 - CONFIGURATION VIA HART®	5.1
CONFIGURATION RESOURCES	5.1
IDENTIFICATION AND MANUFACTURING DATA	5.2
MONITORING	5.2
DEVICE CONFIGURATION	5.2
ADVANCED CONFIGURATION	5.3
DEVICE MAINTENANCE	5.3
TRIM	5.4
AUTOMATIC CONFIGURATION	5.4
MULTIDROP CONFIGURATION	5.4
FACTORY	5.4
SECTION 6 - MAINTENANCE	6.1
GENERAL INFORMATION	6.1
CORRECTIVE MAINTENANCE	6.1
PREVENTIVE MAINTENANCE	6.1
DIAGNOSTICS WITHOUT HART INTERFACE	6.1
DIAGNOSTICS WITH HART INTERFACE	6.3
ELECTRONIC HOUSING MODULE	6.4
REMOVING ELECTRONIC HOUSING MODULE	6.4
REPLACING ELECTRONIC HOUSING MODULE	6.4

TRANSDUCER MODULE	6.5
CONNECTION MODULE	6.5
I/P CONVERTER MODULE	6.6
DIAPHRAGM MODULE	6.8
PNEUMATIC MODULE	6.8
FEEDBACK MODULE	6.10
PACKAGE CONTENT	6.10
ACCESSORIES	6.10
EXPLODED VIEW	6.11
SPARE PARTS LIST	6.12
DETAILED CODE FOR ORDERING SPARE PARTS.....	6.14
ISOLATION TESTE ON EQUIPMENT HOUSING.....	6.16
APPENDIX A – CERTIFICATIONS INFORMATION.....	A.1

Section 1

INSTALLATION

Safety Instructions

This entire section should be read before proceeding with the installation.

- Operating limits are stated in section 3, Technical Characteristics, on this manual.
- The positioner must only be installed, operated, and maintained by qualified personnel with fully trained in field equipment installation.
- Installation in hazardous areas must be in accordance with IEC60079-14 standard.
- Before starting any assembly or disassembly of the actuator/positioner set, the electrical supply and pneumatic supply must be removed. The actuator line must also be emptied. Stay away from moving parts to avoid serious injury.
- When test cycling the actuator and valve assembly by applying pressure to the pneumatic port, be aware that there are moving parts can cause serious injuries.
- The positioner requires instrument air quality, following the best practices for pneumatic installations. Consult the American National Standard "Quality Standard for Instrument Air" (ANSI/ISA S7.0.01 or ISO 8573-1) for detailed information.
- Blow out all piping before connections are made to prevent dirt or debris from entering the positioner. Do not use sealing tape on pneumatic connections. Liquid sealants are recommended for the pipe threads.
- In areas subjected to high relative humidity, the O-rings for the electronic housing covers must be correctly placed and the covers must be completely closed by tighten them by hand until you feel the O-rings being compressed. Do not use tools to tight the covers. Removal of the electronics cover in the field should be reduced to the minimum necessary, since each time it is removed; the circuits are exposed to the humidity.
- The electronic circuit is protected by a humidity proof coating, but frequent exposures to humidity may affect the protection provided. It is also important to keep the covers tightened in place. Every time they are removed, the threads are exposed to corrosion, since painting cannot protect these parts. Sealing methods should be employed on conduit entering of the positioner.

Mounting

The FY500 housing is available in NAMUR and VDI/VDE mounting interfaces. It provides direct mounting to various linear or rotary actuators depending on the actuator mounting method and threaded connection type.



WARNING

The positioner must only be installed, operated, and maintained by qualified personnel with fully trained in field equipment installation.

This product ships with plastic plugs in the conduit entries in an effort to protect the internal components from debris during shipment and handling. Remove plastic plugs only during installation to prevent the intrusion of debris or moisture.

It is the responsibility of the installer, or end user, to install this product in accordance with the national or regional code defining proper practices.

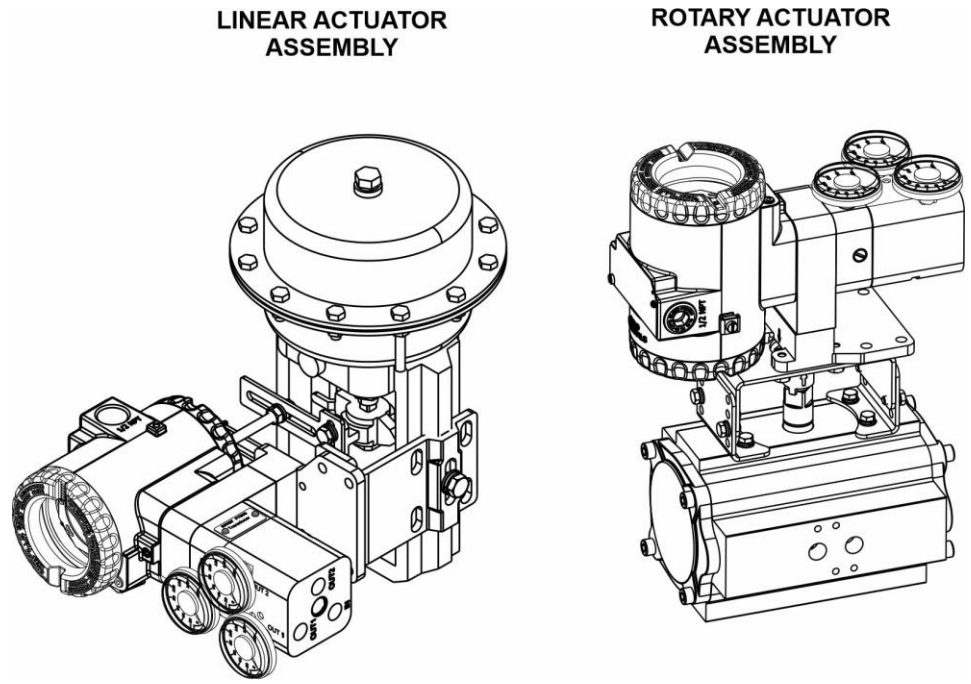

Figure 1.1 – Linear and rotary assemblies



WARNING

Modifying this product, substituting non-factory parts or using maintenance procedures other than outlined could drastically affect performance and be hazardous to personnel and equipment, and may void existing warranties.

On loss of instrument signal, valve will open or close. This identifies whether the valve is fully open or fully closed when the input is 0%. When the input current is removed, the FY500 output 1 should drop to zero.

The following procedures are guidelines to NAMUR linear mounting (DIN IEC 60534-6-1) and NAMUR rotary mounting (VDI/VDE 3845) (DIN EN ISO 5211).

Quarter Turn Rotary Actuators

The FY500 can be mounted in any orientation. The mounting parts kit for the quarter turn actuator contains a mounting bracket with NAMUR VDI/VDE 3845 (DIN EN ISO 5211) standard mounting patterns. See figure 1.2 for the different quarter turn rotary actuator sizes.

QUARTER TURN ROTARY ACTUATOR
 NAMUR VDI/VDE 3845 (DIN EN ISO 5211) STANDARD

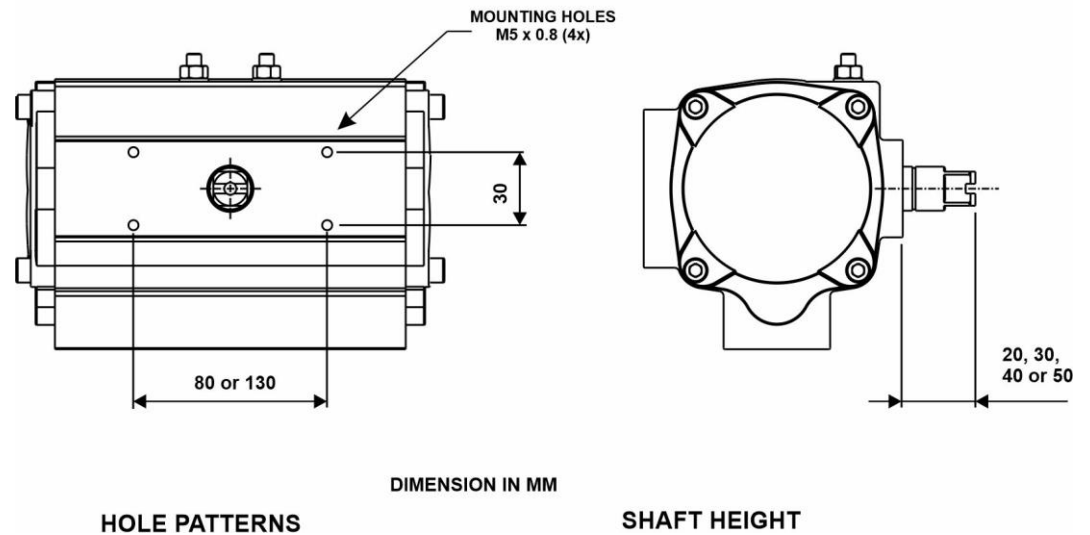

Figure 1.2 – Quarter turn actuator sizes



WARNING

In case of a pneumatic or electrical failure, it is important to know the behavior of the actuator. Before mounting the positioner on an actuator, the failsafe position and direction of rotation of the actuator drive shaft should be verified.



WARNING

Before starting any assembly or disassembly of the actuator/positioner set, the electrical supply and pneumatic supply must be removed. The actuator line must also be emptied. Stay away from moving parts to avoid serious injury.

1. Visually check to make sure the valve is on the fail-safe position. The normal performance of the quarter turn rotary actuators is clockwise-to-close and counterclockwise-to-open. However, this may be inverted under request.
2. Position the rotary actuator to its approximately mid-travel position, using a handwheel or manual loading regulator.
3. The rotary mounting bracket consists of three parts, which can be adjusted to the actuator by different arrangements. Determine the configuration of the rotary bracket, according to dimensions a specific actuator size, using four M5 screws, four lock washers, and four flat washers. as shown in figure 1.3.

TIP

For ease of assembly, attach the L-shaped parts of the mounting bracket only after installing/screwing the rotary adapter.

ROTARY BRACKET MOUNTING

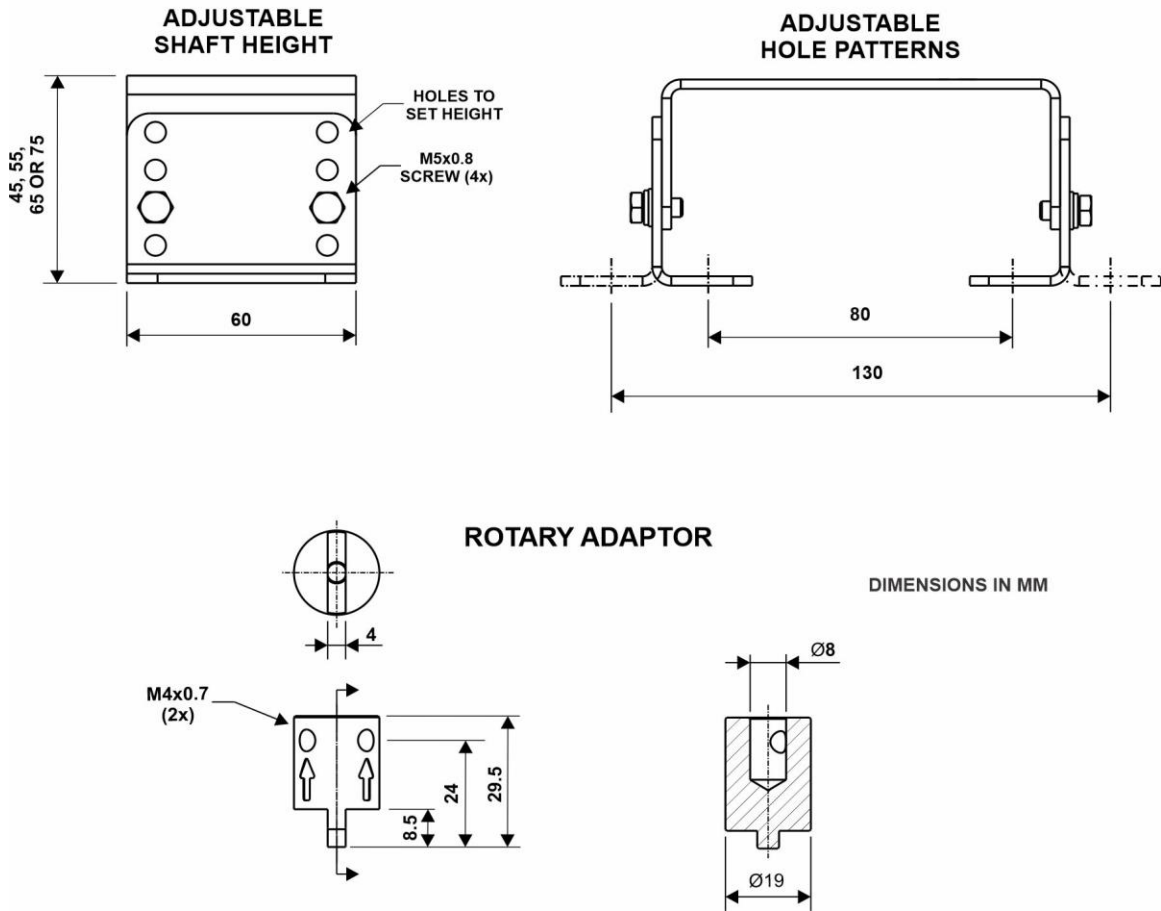

Figure 1.3 – Rotary mounting bracket configuration

4. Before attaching the mounting bracket, determine the orientation of the FY500. It is “IN-LINE” to actuator mounting when the pneumatic connections are in the same direction as the longitudinal drive axis of the actuator, or “ACROSS” to actuator mounting when the pneumatic connections are perpendicular direction as the longitudinal drive axis of the actuator.

5. Position the FY500 on the actuator mounting bracket and secure in place with four M6 x 1 bolts. See figure 1.4.

**POSITIONER "IN-LINE"
TO ACTUATOR MOUNTING**

(pneumatic connections are in the same direction as the longitudinal drive axis of the actuator)

**POSITIONER "ACROSS"
TO ACTUATOR MOUNTING**

(pneumatic connections are perpendicular direction as the longitudinal drive axis of the actuator)

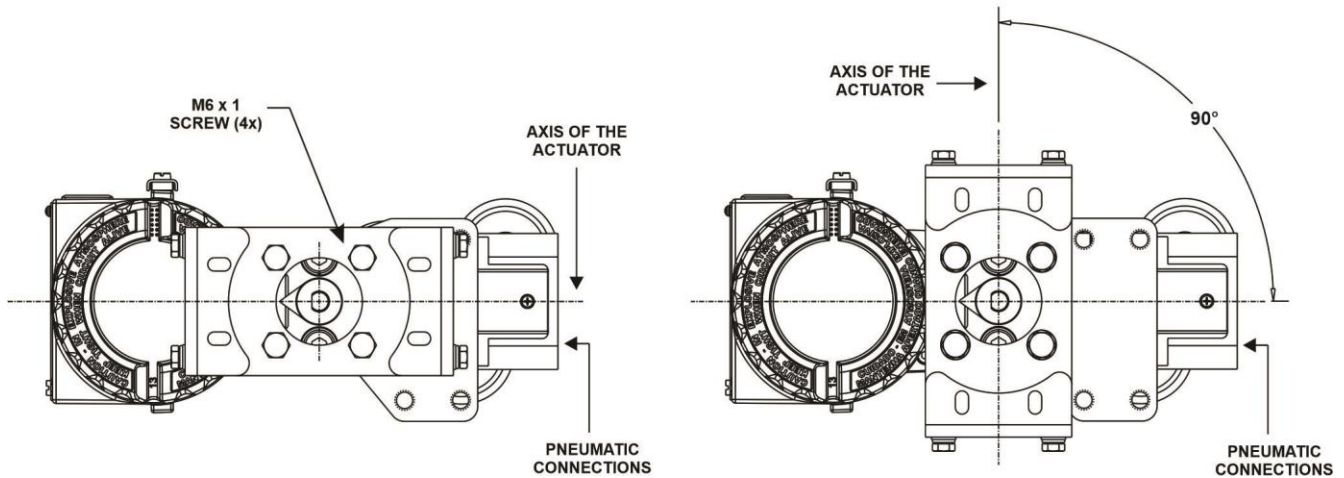

Figure 1.4 – Positioner assembly orientation relative to actuator axis

6. Fit the rotary adaptor onto the feedback shaft of the FY500 and adjust its position on the actuator shaft so that the arrow on the actuator lines up with the arrow mark on the back of the FY500 housing. See figure 1.5.

7. Attach the rotary adaptor to the feedback shaft with one M6 x 10 screw, as shown in figure 1.5. Tighten until the screw fully enters the part.

**INSTALLATION IF POSITIONER IS
"IN-LINE"
TO ACTUATOR MOUNTING**

**INSTALLATION IF POSITIONER IS
"ACROSS"
TO ACTUATOR MOUNTING**

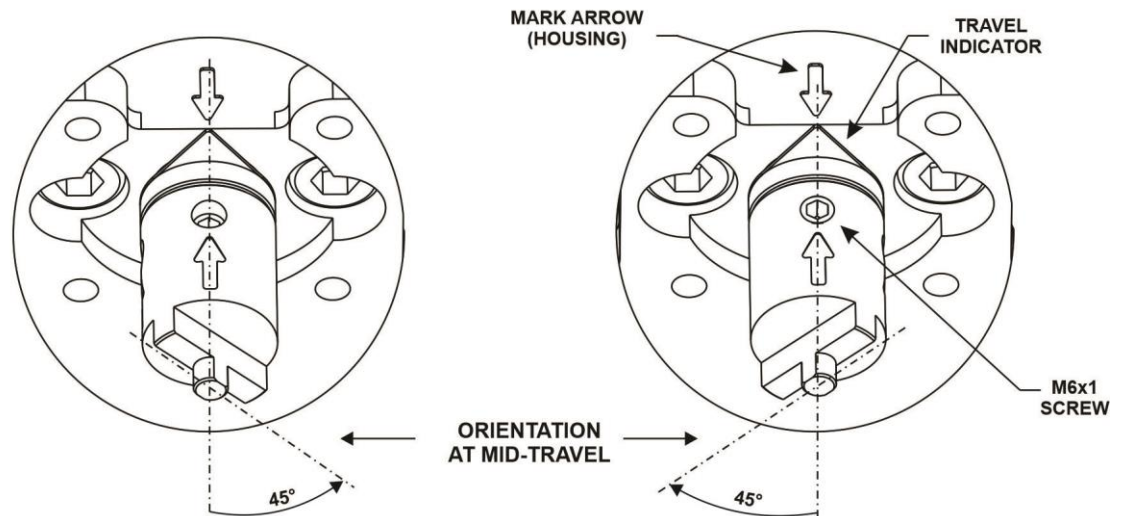

Figure 1.5 – Rotary adaptor assembly orientation on actuator

8. Install the L-shaped parts of the mounting bracket to the FY500, using M6 screws, if not already in place.

9. Install the mounting bracket on the actuator with four M5 x 0.8 screws and flat washers. See figure 1.6. When attaching the FY500 rotary adaptor to the actuator shaft, ensure that the center pin

is fully inserted into the actuator shaft and that the mounting bracket conforms to the configuration shown in figure 1.3.

10. Tighten the mounting bracket screws securely, both those that make it up and those that secure it to the actuator.



WARNING

After installation on the rotary actuator, check that the positioner feedback shaft, adapter and actuator shaft are all aligned. This will avoid friction and other mechanical stresses not designed for parts, increasing their useful life.

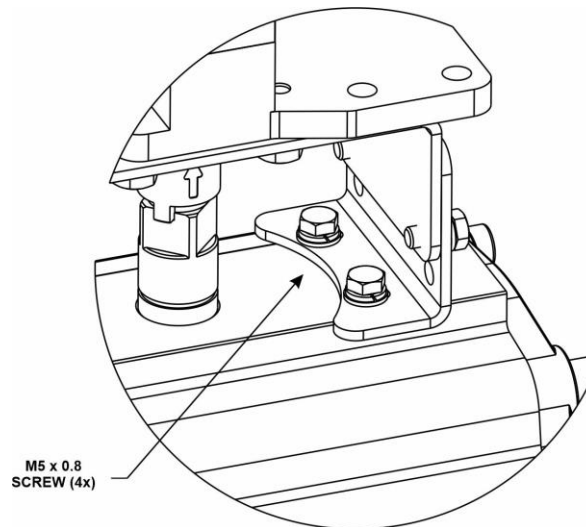

Figure 1.6 – Positioner quarter turn rotary actuator mounting

11. With the actuator at its mid-travel position, the travel indicator is aligned with mark arrow of the housing .

12. Stroke the actuator to each end of its travel. Travel indicator must travel within the admissible range, as shown in figure 1.7.



WARNING

When test cycling the actuator and valve assembly by applying pressure to the pneumatic port, be aware that there are moving parts can cause serious injuries.

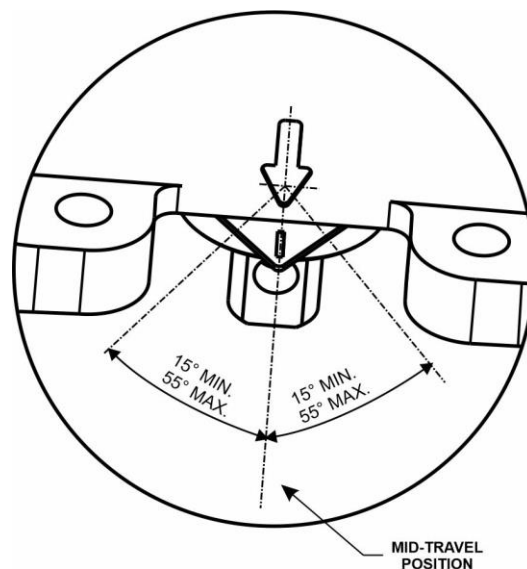

Figure 1.7 – Admissible range – rotary mounting bracket

Linear Actuator

The FY500 can be mounted in any orientation. The mounting parts kit for the linear actuator contains a mounting bracket with NAMUR/IEC 60534-6-1 standard mounting patterns. Applicable to actuators with cast yoke (with rib or plane surface design), or pillar yoke for U-bolt application.



WARNING

In case of a pneumatic or electrical failure, it is important to know the behavior of the actuator. Before mounting the positioner on an actuator, the failsafe position and direction of rotation of the actuator drive shaft should be verified.

The connection between the actuator stem and feedback arm is typically made using a slotted bracket and a feedback pin. There are two ways to transfer the motion through the feedback pin, the **traditional mounting method**, and the **alternate mounting method**.

The Traditional Method

The feedback pin is fixed in the slotted bracket and rides inside the feedback arm.



WARNING

Before starting any assembly or disassembly of the actuator/positioner set, the electrical supply and pneumatic supply must be removed. The actuator line must also be emptied. Stay away from moving parts to avoid serious injury.

1. Attach the feedback pin to the slotted bracket with two M6x1 hex nuts, and two flat washers. Leave the hex nut loose for later adjustment. See figure 1.8.

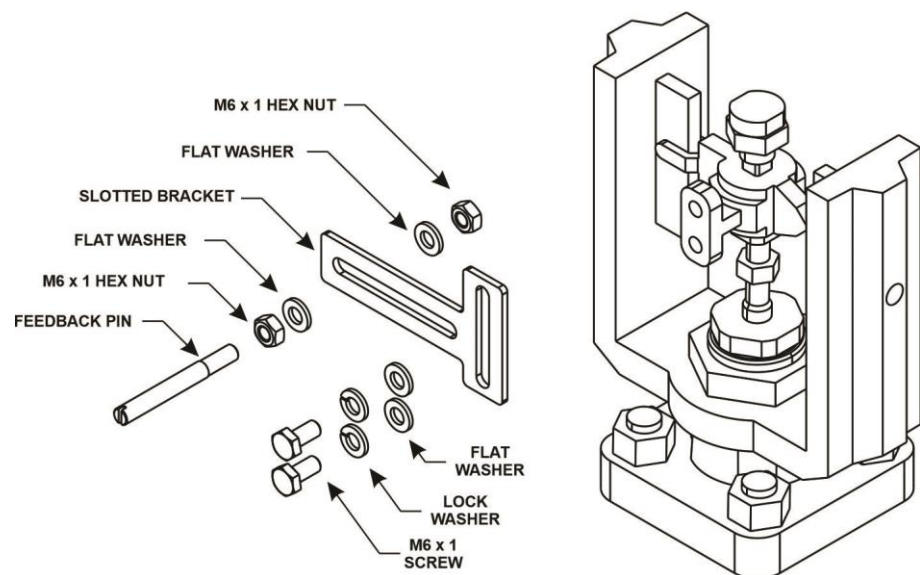

Figure 1.8 – Feedback assembly mounted on actuator stem

2. Attach slotted bracket to the actuator stem with two M6x1 screws, two lock washers, and two flat washers, but do not tighten the fasteners because fine adjustment is required. See figure 1.8.

3. If required, a mounting adaptor is included in the mounting kit. Attach the mounting adaptor to the actuator stem so that the mounting adaptor extends through the yoke leg, then attach the slotted bracket to the adaptor, as shown in figure 1.9. The feedback pin must be on the opposite side of the stem.

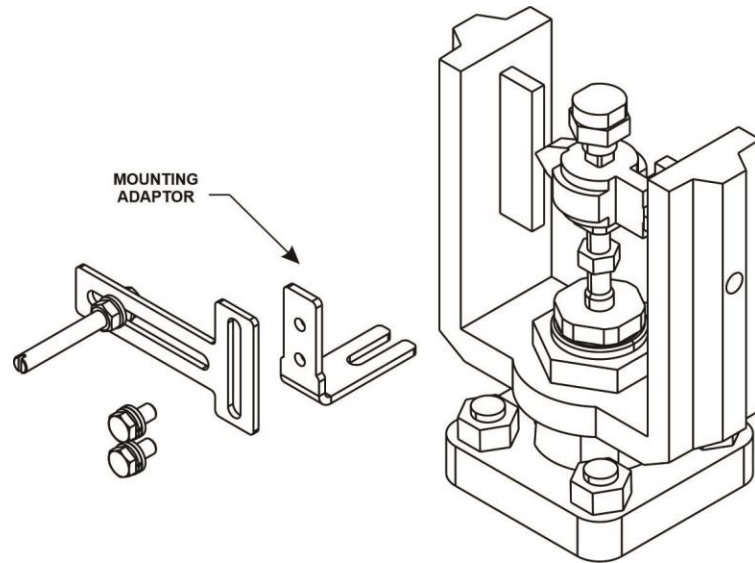

Figure 1.9 – Feedback assembly mounted on mounting adaptor



WARNING

In some cases, attach the slotted bracket to the actuator stem may not be possible, and an mounting adaptor to actuator stem is required. This adaptor will be shipped to the customers according to their purchase order.

4. The FY500 mounts on linear actuators with up to 200 mm (8 inch) travel. Refer to figure 1.10 for the different travel feedback arm sizes depending upon travel of actuator be used.

FEEDBACK ARM - 12 TO 20 mm TRAVEL

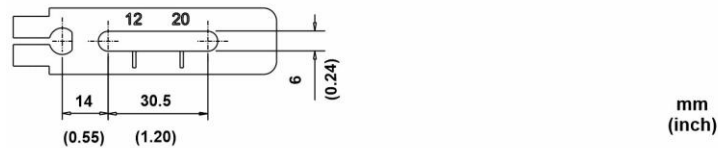

FEEDBACK ARM - 20 TO 60 mm TRAVEL

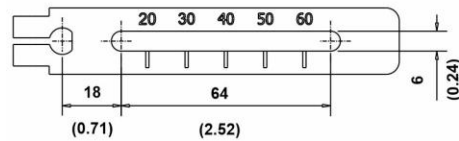

FEEDBACK ARM - 60 TO 120 mm TRAVEL

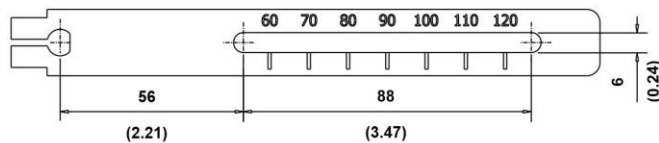

FEEDBACK ARM - 120 TO 200 mm TRAVEL

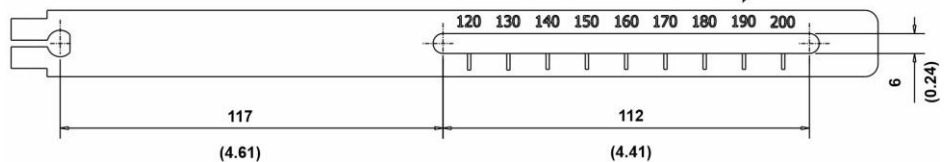

Figure 1.10 – Feedback arm sizes

5. Attach the feedback arm to the end of the feedback shaft with M6x1 screw, M6 hex nuts, lock washers, and flat washers. The markings on the feedback arm must be visible to the operator/installer. Install the compensating spring on the feedback arm. See figure 1.11.

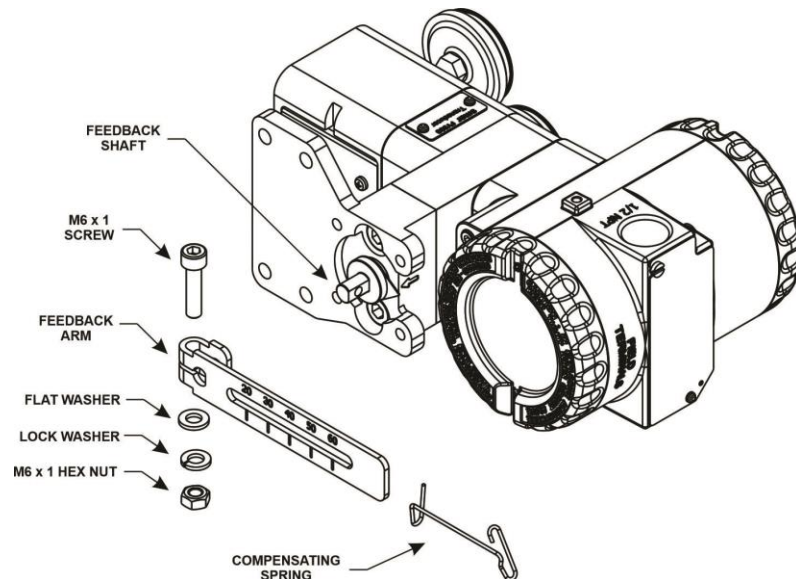

Figure 1.11 – Feedback arm assembly



WARNING

The compensating spring is used to hold the feedback pin securely against one side of the feedback arm slot. This prevents excessive play in the linkage and limits the amount of error introduced into the system through the linkage.

6. Refer to figure 1.12. Mount the positioner to the mounting bracket using two M8x1.25 screws, two lock washers, and two flat washers.

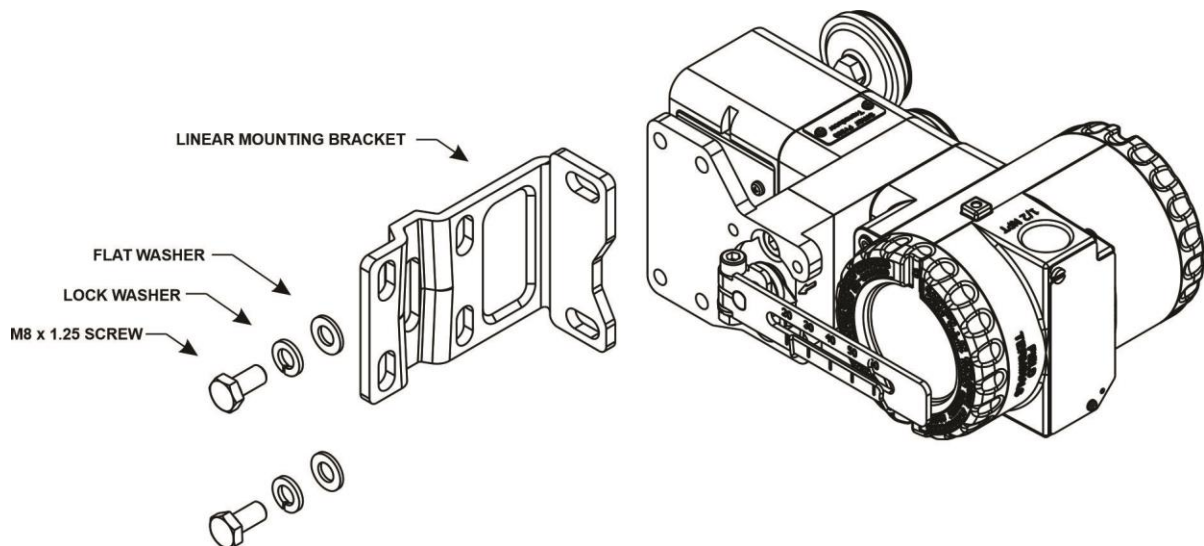

Figure 1.12 – Positioner mounting bracket

7. Position the actuator to its mid-travel position using a handwheel or manual loading regulator.

8. Adjust the vertical position of the slotted bracket so that the feedback arm and oblong arm are horizontally aligned. The feedback pin must be in the mark on the feedback arm that indicates the valve stroke size (see marking on cast yoke). Tighten the M6x1 screws.

9. Before installing the mounting bracket to the actuator yoke, slip the round end of the feedback pin into the feedback arm slot. Make sure the feedback pin engages the slot in the feedback arm.

Secure the mounting bracket to the actuator yoke using the follow procedures:

- **For actuators with cast yoke with rib surface application**, using the M8x1.25 screw, lock washer, and flat washer. See figure 1.13.

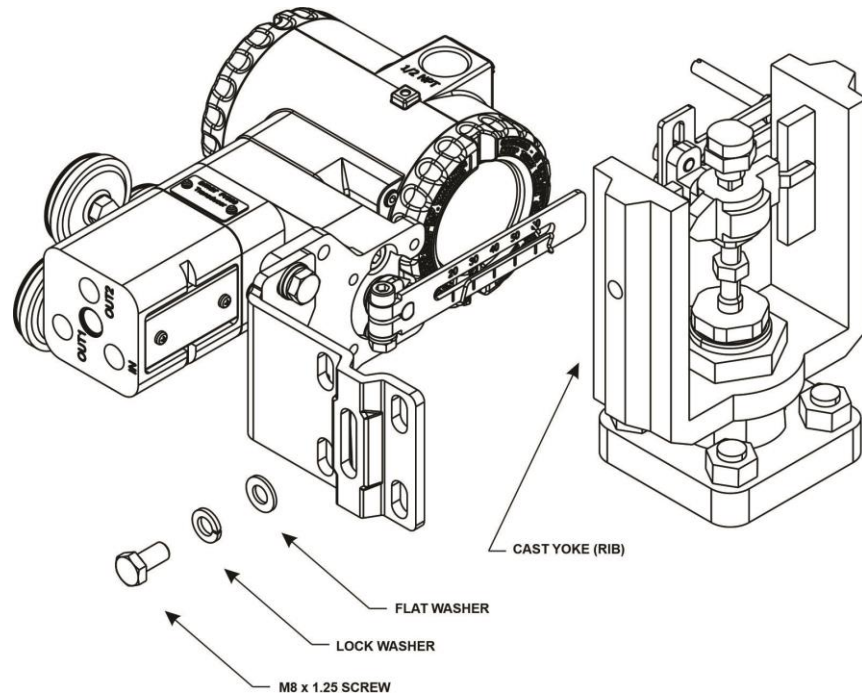

Figure 1.13 – Attachment to cast yoke with rib surface

- **For actuators with cast yoke with plane surface application**, using two 5/16 – 18 UNC screws, two lock washers, and two flat washers. See figure 1.14.

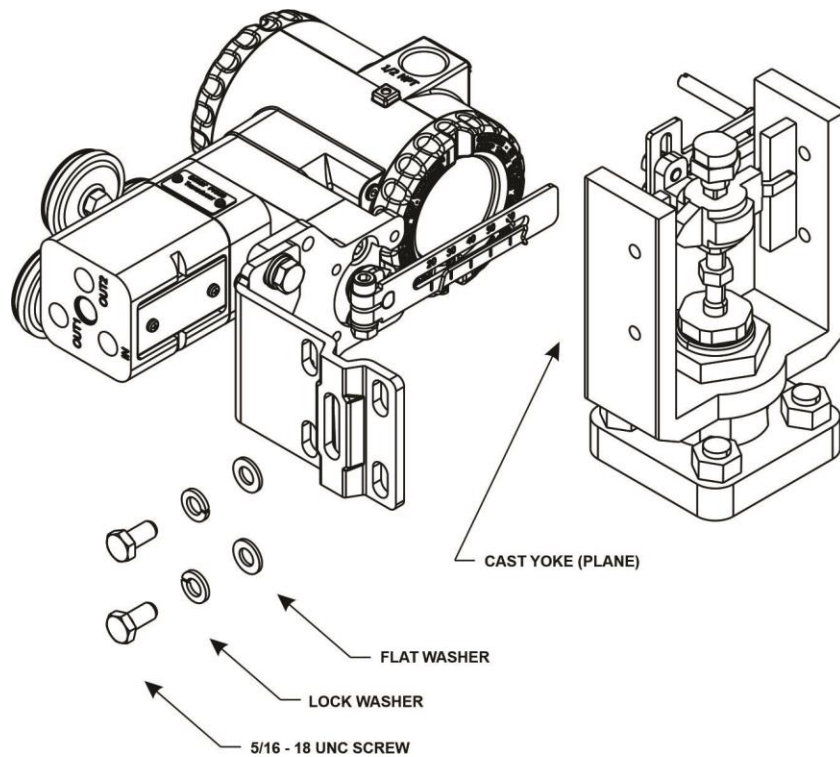

Figure 1.14 – Attachment to cast yoke with plane surface

- For actuator with pillar yoke for U-bolt application, using two U-bolt, four lock washers, and four flat washers, as shown in figure 1.15.

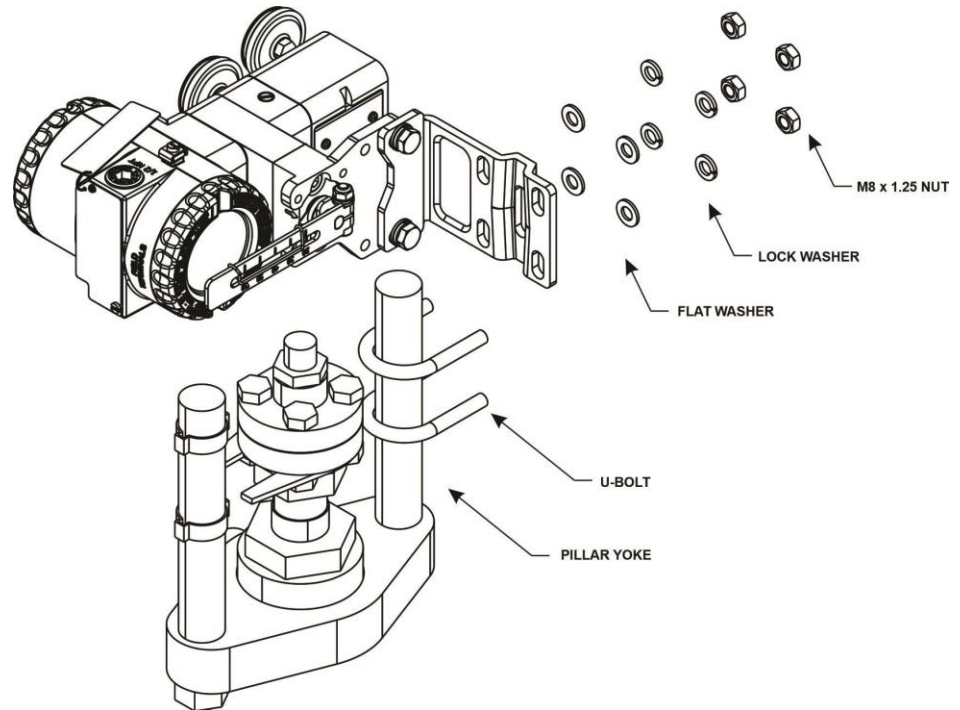

Figure 1.15 – Attachment to pillar yoke for U-bolt

- Slide the adjustment feedback pin in the slot of the slotted bracket until the pin is in line with the desired actuator travel marking on the feedback arm. The compensating spring must be positioned such that the feedback pin sits in the central side of the compensating spring's slide area. Tighten the hex nuts. As shown in **figure 1.16**.

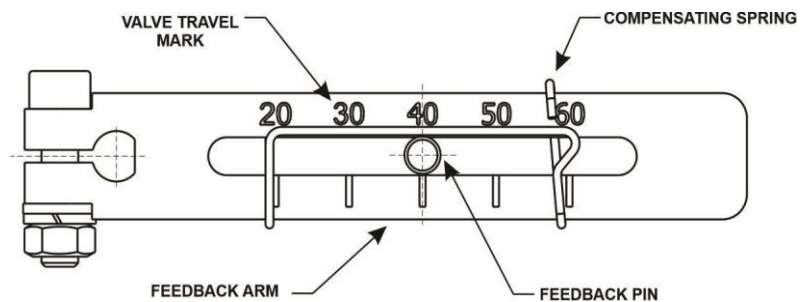

Figure 1.16 – Positioning feedback pin in feedback arm

- With the actuator at its mid-travel position, adjust the mounting bracket location vertically so that the feedback arm is perpendicular to the stem, as shown in figure 1.17.
- Stroke the actuator from the top stop to the bottom stop. Travel indicator must travel within the admissible range. See figure 1.17.

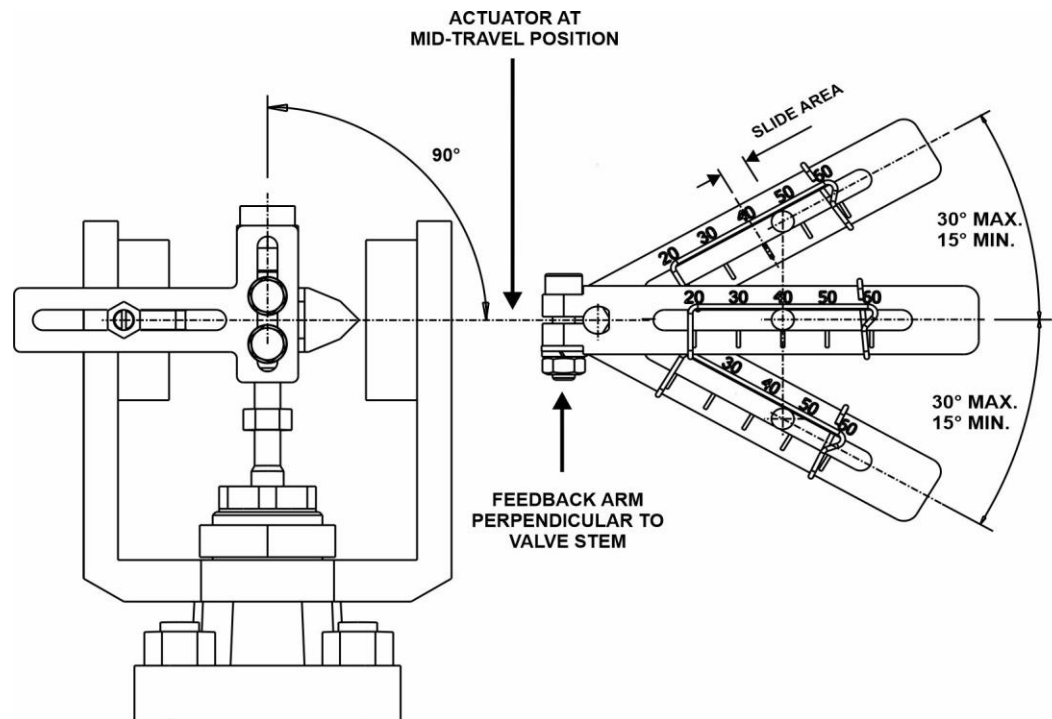

Figure 1.17 – Admissible range – linear mounting bracket



WARNING

When test cycling the actuator and valve assembly by applying pressure to the pneumatic port, be aware that there are moving parts can cause serious injuries.

The Alternate Method

The feedback pin is fixed in the feedback arm and have it ride freely inside the slotted bracket.



WARNING

Before starting any assembly or disassembly of the actuator/positioner set, the electrical supply and pneumatic supply must be removed. The actuator line must also be emptied. Stay away from moving parts to avoid serious injury.

1. Install the compensating spring on the slotted bracket.
2. Attach the feedback pin to the feedback arm with two M6x1 hex nuts, and two flat washers. Adjust the position of the feedback pin so that the center aligns with the appropriate travel mark on the feedback arm.
3. Complete the assembly procedure described in **The Traditional Method** topic of this manual.

Pneumatic Connections

The FY500 requires instrument air quality, following the best practices for pneumatic installations. Consult the American National Standard "Quality Standard for Instrument Air" (ANSI/ISA S7.0.01 – 1996) for detailed information. Instrument air shall have the following characteristics:

Dew point	10°C below minimum instrument temperature.
Size of particles	40 µm (maximum).
Oil content	1 ppm w/w (maximum).
Contaminants	Free of corrosive contaminants and hazardous gases.

The instrument air quality shall be superior to that of industrial compressed air. Humidity, suspended particles and oil contamination, even lubricating oil, may impair the instrument operation, either temporarily or permanently in case of internal parts wearing.

The mentioned standard recommends to place the compressor intake in an environment free from process spills, contaminants, and to use adequate filters. Also, the compressors must be of non-lubricated type to prevent the presence of lubricants. When using lubricated compressors, the plant must have resources to remove the lubricant from the instrument air supplied.

The supply pressure varies from 2 bar (30 psi) minimum, to 10.3 bar (150 psi) maximum. The FY500 requires sufficient supply pressure to stroke the actuator to each end of its travel.

Maximum allowable air supply pressure to the positioner must not exceed 10.3 bar (150 psi). For actuator pressure refer to the appropriate actuator instruction manual.



WARNING

- Never exceed maximum supply pressure. Injury to personnel or damage to the equipment may result.
- Supply pressure to positioner should not exceed actuator maximum pressure rating.
- Blow out all piping before connections are made to prevent dirt, chips, or debris from entering the positioner.
- Use a pipe sealant sparingly and only on male threads. It is not recommended to use a sealing tape on pneumatic connections.

The positioner vents the supply medium into the surrounding atmosphere through holes located in the positioner vent cover, as shown in figure 1.18. The positioner does not have an external vent connection. Do not restrict the vent opening. Restricting the vent opening can produce a pressure buildup in the positioner valve spool and degrade positioner performance. Ensure that the housing vent opening is open and free of debris to prevent pressure buildup under the cover.

Connect the power supply to the 1/4 NPT IN connection on the positioner. The output connections 1/4 NPT OUT1 and OUT2 must be connected to the actuator. For best response times use tubing of 3/8-inch minimum size. See figure 1.18.



WARNING

When the input current is removed, the FY500 OUT1 should drop to zero and OUT2 register full pressure.

When using a positioner on a single acting actuator, close OUT2 and connect OUT1 to the actuator pneumatic input.

When using a positioner on a double acting actuator, connect OUT1 and OUT2 to the appropriate actuator pneumatic input. When the input current is removed, the FY500 OUT1 should drop to zero and OUT2 register full pressure.

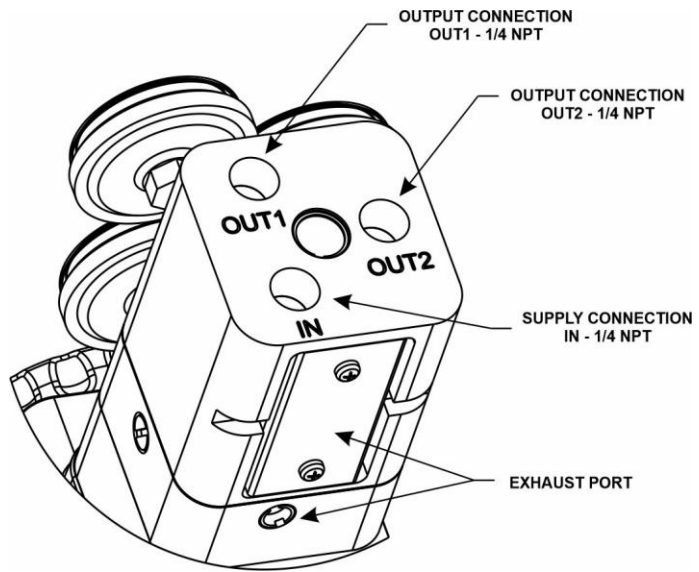

Figure 1.18 – Pneumatic connections

Dimensional Drawings

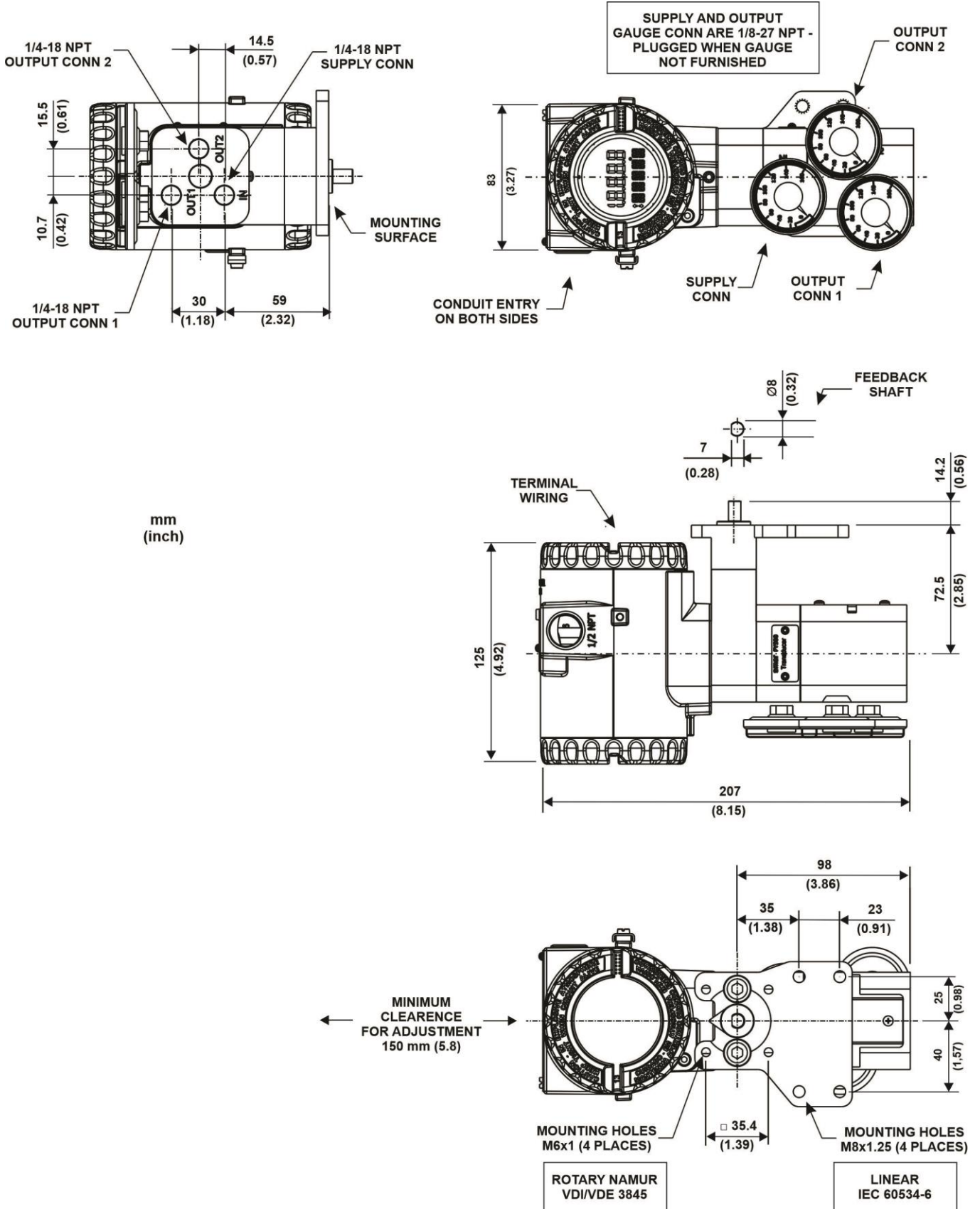

Figure 1.19 – Dimensional drawings

Electrical Wiring

The FY500 is normally powered by a control system output card (PLC). Wire size requirements are 14 AWG maximum, 26 AWG minimum. For environments with high EMI interference levels, the use of shielded cables should be observed. Avoid routing signal wiring near to power cables or switching equipment.

The conduit connection must be sealed according to the hazardous area standards. The unused cable entries should be plugged and sealed accordingly to avoid humidity entering, which can cause the loss of the product's warranty. See figure 1.20.

Use the 1/2 inch NPT (or M20 thread) conduit connection for field wiring installation.



WARNING

In hazardous areas with explosion proof requirements, the covers must be tightened with at least 8 turns. To avoid the penetration of humidity or corrosive gases, tighten the o-ring until feeling it touching the housing. Then, tighten more 1/3 turn (120°) to guarantee the sealing. Lock the covers using the locking bolts.

Conduit threads should be sealed by means of code-approved sealing methods.

The FY500 is designed to withstand explosion proof, non-incendive, and intrinsic safety.

For a complete list of available certificates, please consult <http://www.smar.com>.

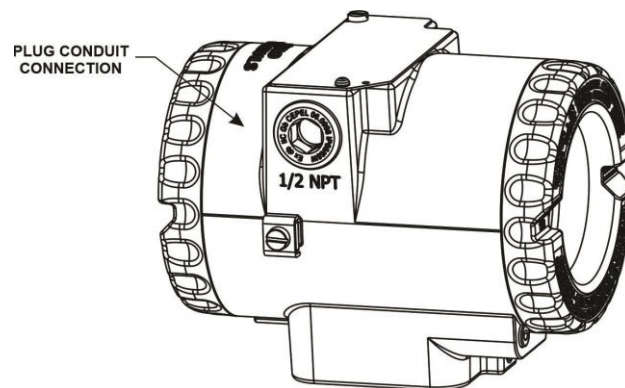

Figure 1.20 – Plug Mounting

4 – 20 mA Loop Connections

The FY500 is normally powered by a control system output card (PLC). Shielded cable will ensure proper operation in electrically noisy environments. Wire the positioner as follows:

1. Loose the cover locking screw and remove the terminal block cover as shown in figure 1.21.

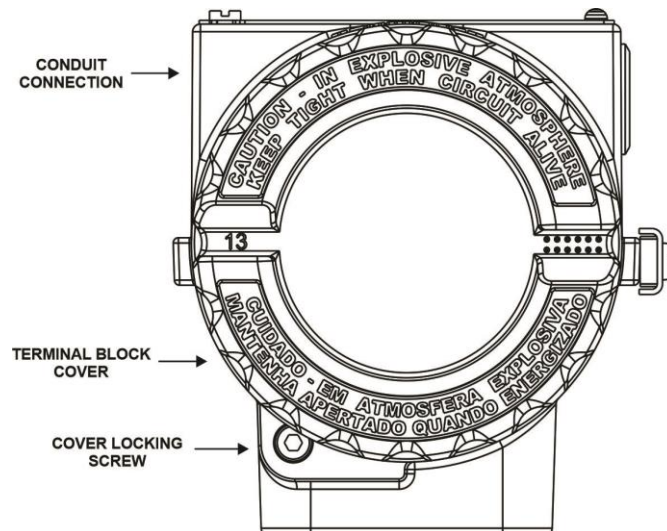

Figure 1.21 – Cover Locking Screw

2. Connect the positive wire to the (+) screw terminal and the negative wire to the (-) screw terminal, As shown in figure 1.22.
3. Two ground terminals are available on electronic housing: one internal and one external. Both are grounded in the housing itself. It is recommended to ground the cable shield at only one end. The cable shielding mesh, if exposed, needs to be insulated so that it does not come into contact with the power supply terminals, for example with heat-shrink tube or insulating tape.
4. Replace and hand tighten the cover. To secure the cover engage the locking screw.

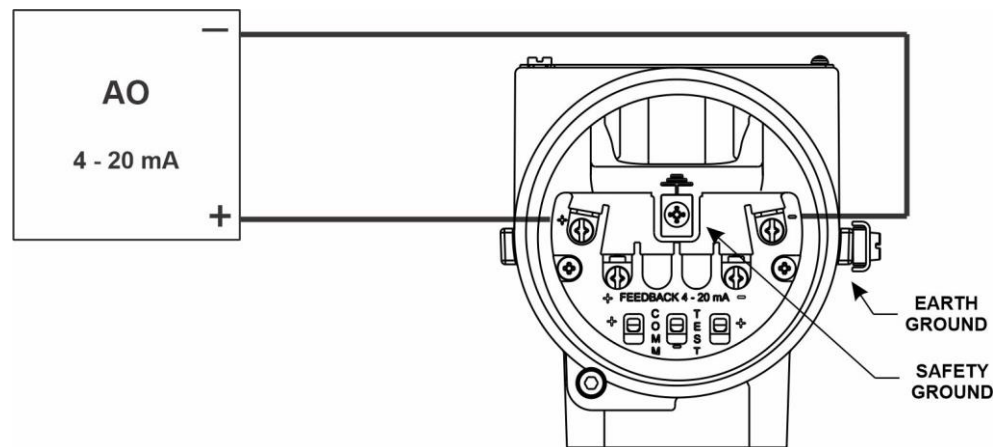

Figure 1.22 – Loop connections

Test Connections

Test terminals allow to measure the current in the 4 - 20 mA loop, without opening the circuit.

1. Remove the terminal block cover as shown in figure 1.21.
2. Connect the positive terminal of the test meter to the (TEST +) and negative terminal of the test meter to the (TEST -). See next figure.

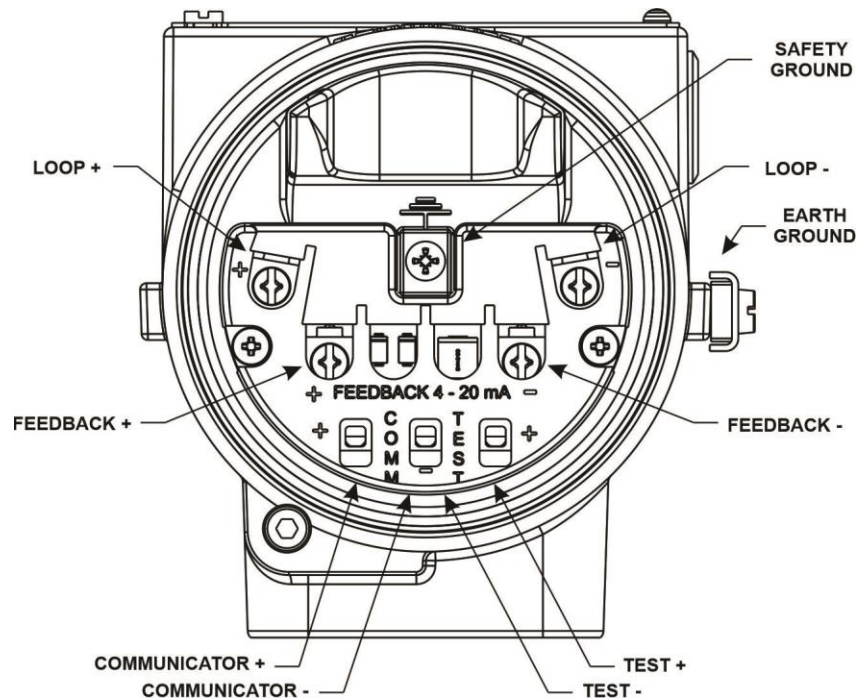

Figure 1.23 – Terminal Block

3. Measure the loop current.
5. Remove test cable. Replace and hand tighten the terminal cover. To secure the terminal block cover engage the locking screw.

Communication Connections

The HART communication interface can be connected to the 4 to 20 mA loop wiring or directly to the appropriate terminals on the FY500 terminal block.

1. Remove the terminal block cover as shown in figure 1.21.
2. Attach the clip-on wires provided with HART interface to COMM terminals, or the (+) and (–) screws terminals, in the FY500 terminal block, as shown in figure 1.23.
3. After the configuration, remove the clip-on wires. Replace and hand tighten the terminal cover. To secure the terminal block cover engage the locking screw.

Feedback Connections

1. Loosen the cover locking screw and remove the terminal block cover as shown in figure 1.21.
2. Connect the positive wire from the control system input card to the FEEDBACK + terminal. Connect the negative wire from the control system input card to the FEEDBACK - terminal. See figure 1.24.
3. Replace and hand tighten the cover. To secure the terminal block cover engage the locking screw.

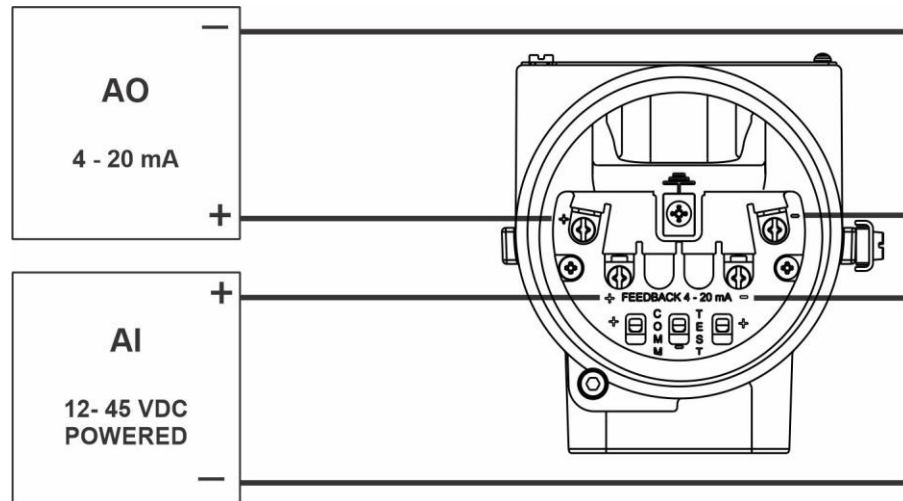

Figure 1.24 – Feedback connections

Electronic Housing Rotation

The electronic housing can be rotated to offer a better display position and/or better access to the field cables.



WARNING

To avoid damage do not rotate the electronic housing more than 270° starting from the fully threaded without disconnecting the electronic circuit from the printed circuit board and from the power supply.

1. Loosen the rotation locking screw. See figure 1.25
2. Rotates the electronic housing to the desired position. Observe if the flat cable is not excessively twisted. See figure 1.26.
3. Tighten the rotation locking screw.

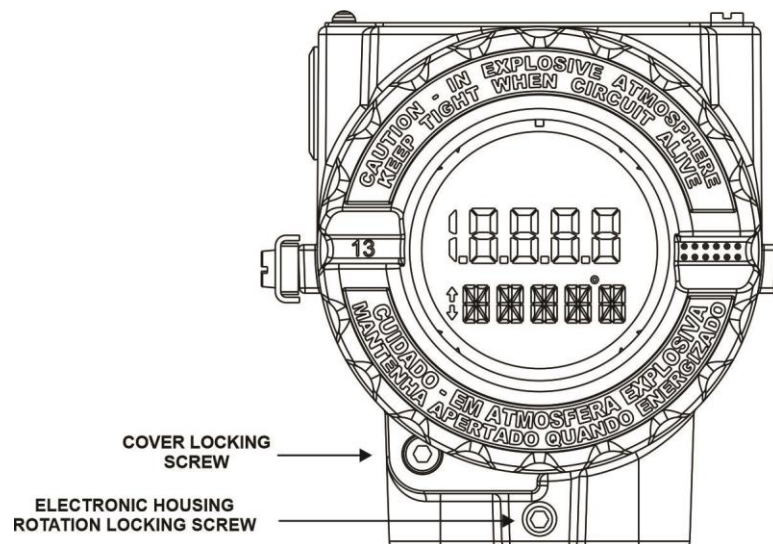

Figure 1.25– Electronic housing rotation locking screw

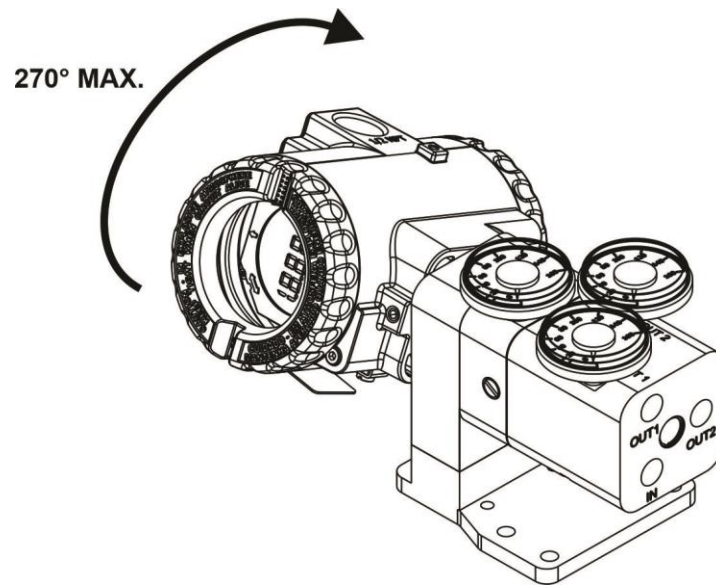

Figure 1.26– Electronic housing rotation

Changing the Display Position

There are four ways to position the display on the housing.

1. Loosen the cover locking screw and remove the cover, as shown in figure 1.21.
2. Loosen the four captive display screws and rotate the display to the desired position. The arrow molded into the piece indicates the reading position. See next figure.
3. Tighten the captive display screws. Replace and hand tighten the terminal block cover.

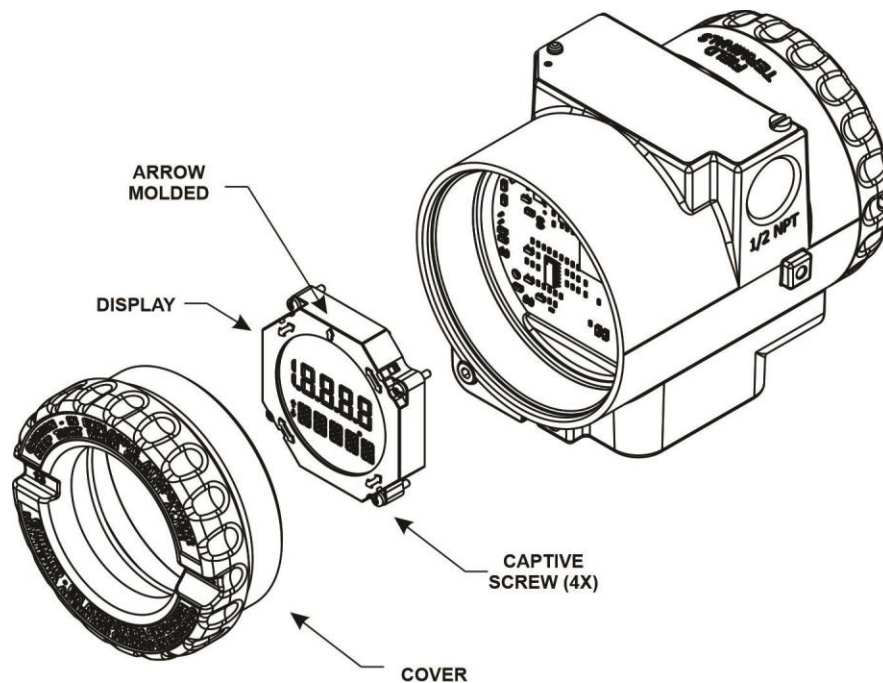

Figure 1.27 – Changing the display position

Typical Applications

The FY500 connection should be done accordingly following applications, as shown in figures 1.28 and 1.29.

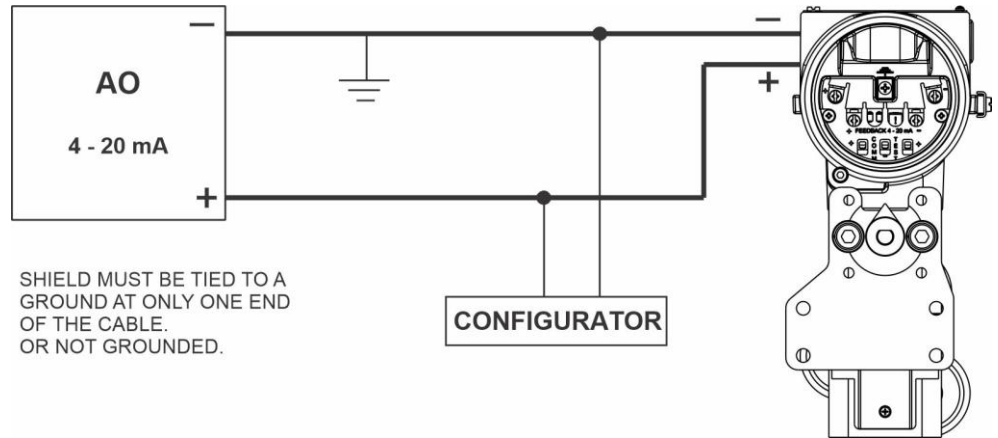

Figure 1.28 – Connecting FY500 to the controller

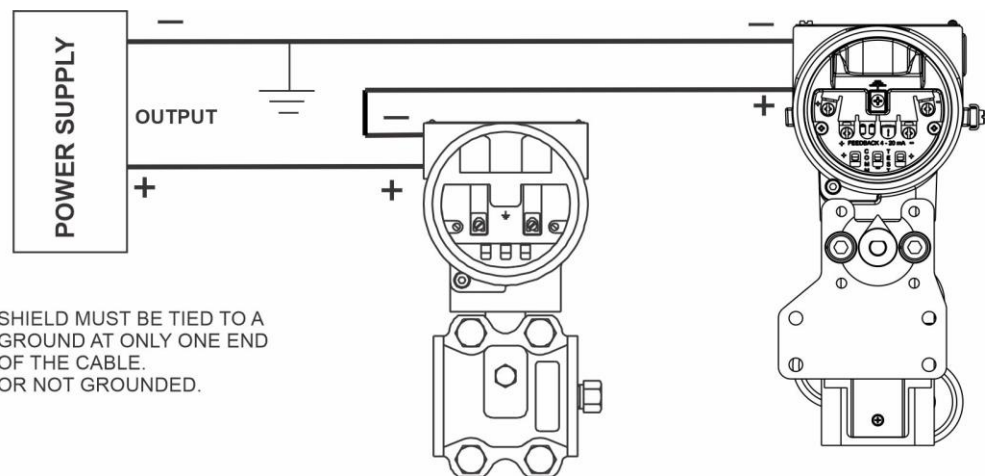

Figure 1.29 – Connecting the FY500 to the pressure transmitter



WARNING

Connect the FY500 to a 4 to 20 mA current source, the positioner will not operate when connected to a voltage source.

Split-Range Operation

The FY500 can be used for split range operation, when a single current output from a control system is used to operate two actuator/valve assemblies. One of the sets will move its entire course between 4 and 12 mA, for example, while the other will do the same from 12 to 20 mA.

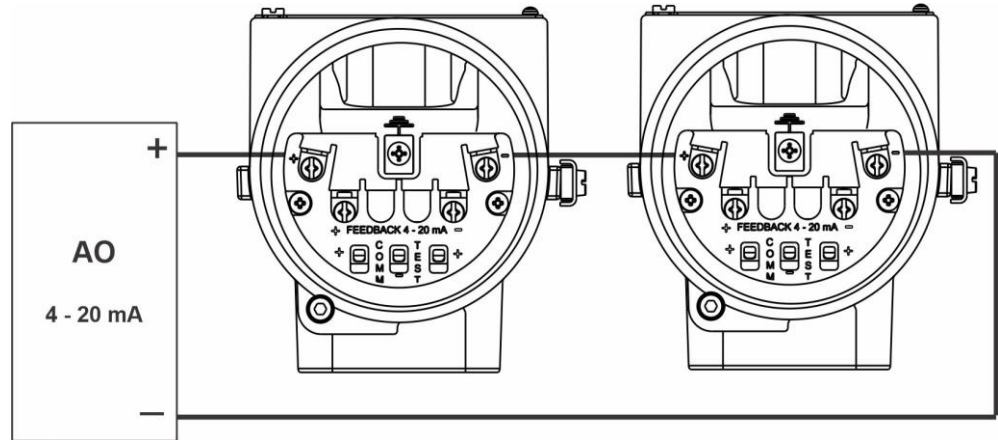

Figure 1.30 – Split range operation

Installation in Hazardous Areas



WARNING

Explosions could result in death or serious injury, besides financial damage. Installation of this positioner in explosive areas must be carried out in accordance with the local standards and the protection type adopted. Before continuing the installation make sure the certificate parameters are in accordance with the classified area where the equipment will be installed.

The instrument modification or parts replacement supplied by other than authorized representative of Smar is prohibited and will void the certification.

The positioners are marked with options of the protection type. The certification is valid only when the protection type is indicated by the user. Once a particular type of protection is selected, any other type of protection cannot be used.

The electronic housing and the position sensor installed in hazardous areas must have a minimum of 6 fully engaged threads. Lock the housing using the locking screw (Figure 1.10).

The cover must be tightened with at least 8 turns to avoid the penetration of humidity or corrosive gases. The cover must be tightened until it touches the housing. Then, tighten more 1/3 turn (120°) to guarantee the sealing. Lock the covers using the locking screw (Figure 1.10).

Explosion/Flame Proof



WARNING

In Explosion-Proof installations, the cable entries must be connected or closed using metal cable gland and metal blanking plug, both with at least IP66 and Ex-d certification.

As the positioner is non-ignition capable under normal conditions, the statement "Seal not Required" could be applied for Explosion Proof Version.

The standard plugs provided by Smar are certified according to international standards. If the plug needs to be replaced, a certified plug must be used.

The electrical connection with NPT thread must use waterproofing sealant. A non-hardening silicone sealant is recommended.

Do not remove the positioner covers when power is ON.

Intrinsically Safe



WARNING

In hazardous zones with intrinsically safe or non-incendive requirements, the circuit entity parameters and applicable installation procedures must be observed.

To protect the application the positioner must be connected to a barrier. Match the parameters between barrier and the equipment (Consider the cable parameters). Associated apparatus ground bus shall be insulated from panels and mounting enclosures. Shield is optional. If used, be sure to insulate the end not grounded. Cable capacitance and inductance plus C_i and L_i must be smaller than C_o and L_o of the associated Apparatus.

For free access to the HART bus in explosive environment, ensure the instruments in the loop are installed in accordance with intrinsically safe or non-incendive field wiring practices. Use only Ex HART communicator approved according to the type of protection Ex-i (IS) or Ex-n (NI).

It is not recommended to remove the positioner cover when the power is on.

NOTE

To obtain all the available certifications consult www.smar.com.

OPERATION

Principle of Operation

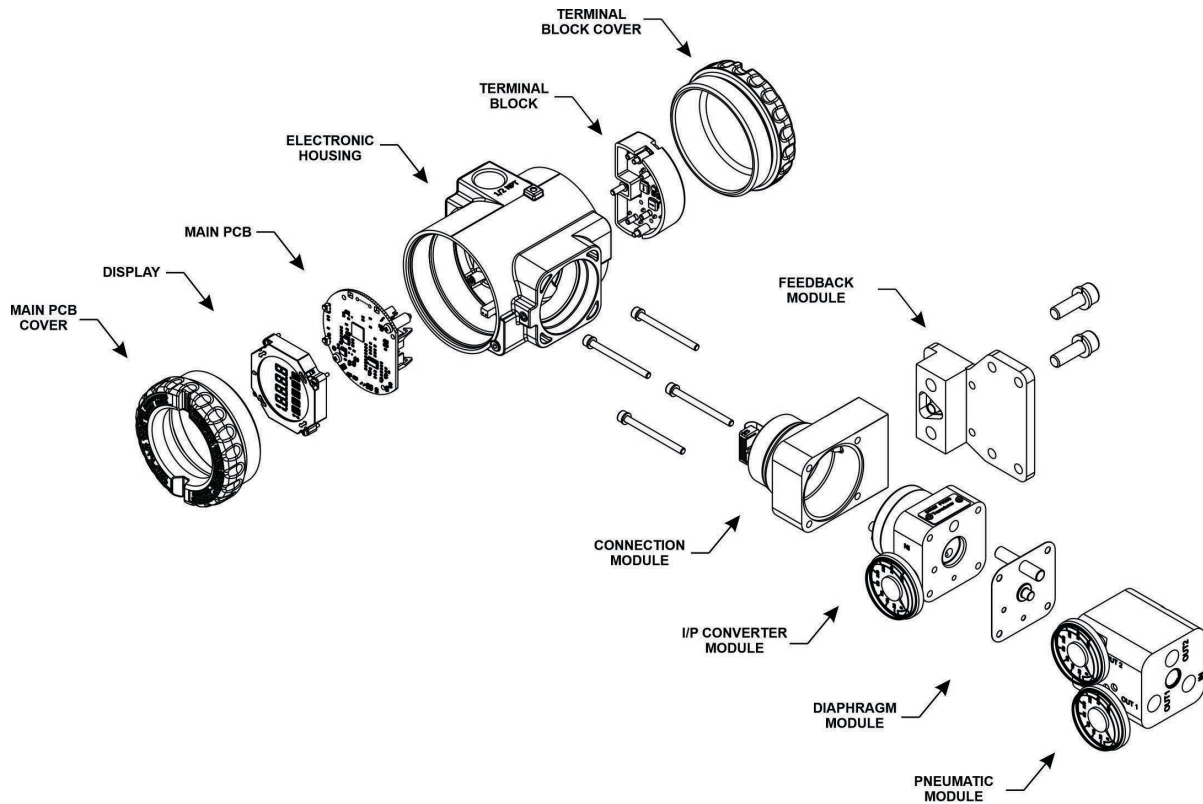

Figure 2.1 – FY500 Digital Valve Positioner (Exploded View)

The FY500 receives a setpoint signal from a controller or other device through a twisted pair of wires. It compares this input signal to the actual valve position, which is measured with a position sensor, in this case, Hall Effect sensor. The difference between the setpoint and the actual position is processed by internal PID, and a corrective current signal is sent to the I/P converter module.

The supply pressure to the FY500 passes through an internal pressure regulator that regulates it to approximately 22 psi. The air then goes through an orifice that restricts the flow and air consumption. The I/P module converts the current signal to a pneumatic signal, which is sent to the diaphragm module and the spool valve. The spool valve directs air supply to the actuator to move the valve until the Hall Effect Sensor reading agrees with the setpoint.

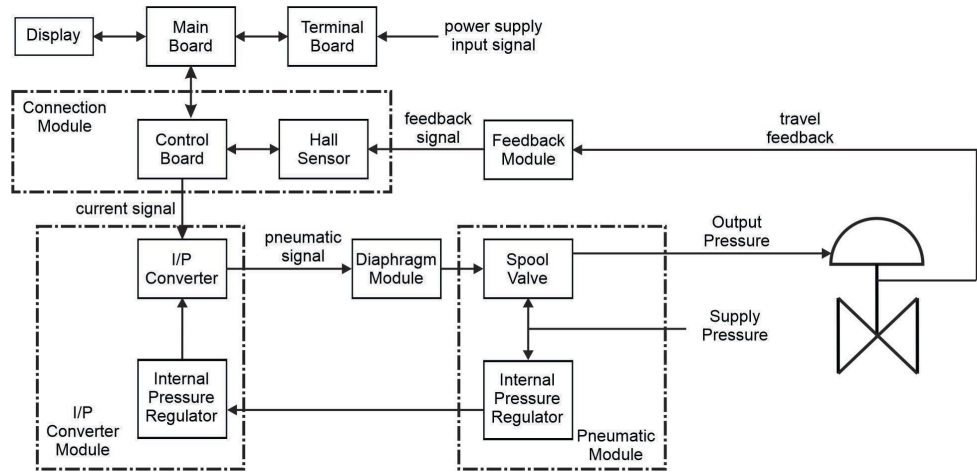

Figure 2.2 – FY500 Block Diagram

Display

The digital display LCD is necessary to show the information, such as measured variable and its unit, and to perform the local adjustment.

During the normal operation, the FY500 stay in the monitoring mode and the display shows the valve position in percentage. During the configuration process, there is an option to show the setpoint on the display. The local programming mode is activated by approximating the magnetic tool to the hole marked by the letter "Z", on the top of the electronic housing.

The Figures 2.3 and 2.4 show the possible configuration indications and monitoring information.

When powering the **FY500**, the display shows the **FY500** model, its firmware version, and the communication protocol.

Monitoring

During normal operation, the **FY500** remains in the monitoring mode. The display on Figure 2.3 shows the valve position in percentage.

On the position marked with "Z", the magnetic tool moves forward through the programming tree to the next menu item or increments the currently shown value in the digital display. Holding down the magnetic tool causes the value to increase at a faster rate.

On the position marked with "S" the magnetic tool selects or accepts the value or parameter option currently displayed. (More details in the Section 4).

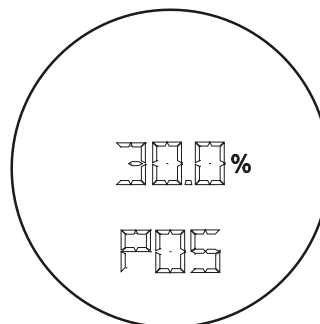

Figure 2.3 – Typical Display

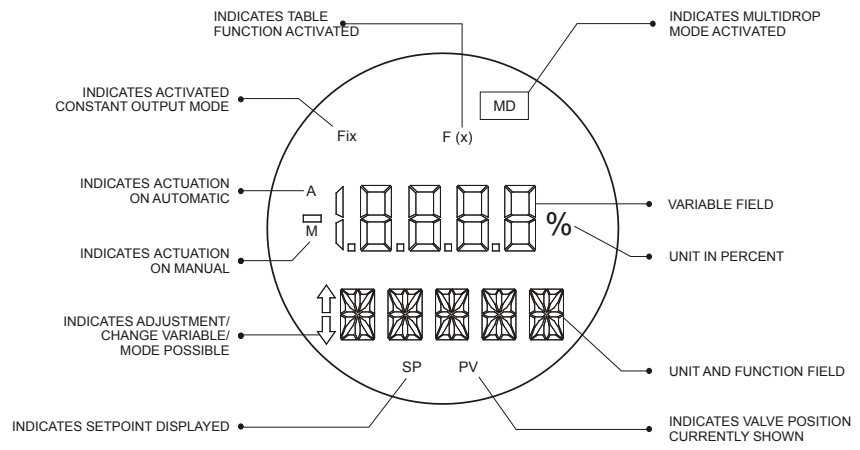

Figure 2.4 – Local Display

Section 3

TECHNICAL CHARACTERISTICS

Functional Specifications

Input and Communication Protocol	HART® Two-wire, 4-20 mA Voltage Drop 9.5 Vdc Max / 20 mA (equivalent to 475 Ω) Minimum Control Current: 3.8 mA controlled according to NAMUR NE43 specification, with super-imposed digital HART Protocol.
Humidity Limits	0 to 100% RH (Relative Humidity non-condensable).
Travel	Linear actuator stroke: 12 - 200 mm. Rotary actuator: 30° - 120° Rotation Angle.
Indicator	Rotative LCD, with 4½-numerical digit and 5-character alphanumeric. Function and status icons.
Pressure Supply	2 - 10 bar (30-150 psi). Free of oil, dust, and water, as per ANSI/ISA S7.0.01-1996.
Gauge	For pressure monitoring supply and output, 0 to 160 psi scale. Acrylic display, 304 Stainless Steel connections and flexible parts in Brass.
Flow Characterization	Linear, Equal Percentage, Quick Opening, 16-point freely configurable table.
Temperature Limits	Operation: -40 to 85 °C (-40 to 185 °F). Storage: -40 to 90 °C (-40 to 194 °F).
Configuration	Through HART digital communication over 4-20mA signal. The FY500 can be configured either via FDT/DTM tools or via DD-based configurators. It can also be configured through local adjustment using Smar's magnetic tool.
Hazardous Area Certifications	Intrinsically safe and explosion proof.
European Directive Information	FY500 is in compliance with the directive. It was designed and manufactured in accordance with good engineering practices using ANSI, ASTM, DIN and JIS standards. Quality Management System audited by BVQI (Bureau Veritas Quality International) for the Management Systems certification. EMC Directive (2014/30/EU) – Electromagnetic Compatibility The EMC test was performed according to standard: IEC61326:2002 ATEX Directive (2014/34/EU) - Explosive Atmosphere, Hazardous Location

Performance Specifications

Independent Linearity	±0.5% of output span ^(1,2)
Air Consumption	0.31 scfm (0.49 normal m3/hr) @ 60 psig (4.1 bar) supply pressure ⁽¹⁾
Output Capacity	11 scfm (20.5 normal m3/hr) @ 60 psig (4.1 bar) supply pressure ⁽¹⁾
Vibration Effect	Tested per ANSI/ISA-75.13.01 Section 5.3.5.
Ambient Temperature Effect	0.8% / 20°C of output span ⁽¹⁾
Electromagnetic Interference Effect	Meets IEC 61326:2002

1. Measured according to ANSI / ISA-75.13.01-2013

2. Typical value. Not applicable for ACP mounting brackets applications

Physical Specifications

Electrical Connections	1/2-14 NPT 1/2-14 NPT with 3/4-14 NPT adaptor (AISI316) 1/2-14 NPT with 3/4-14 BSP adaptor (AISI316) 1/2-14 NPT with 1/2-14 BSP adaptor (AISI316) M20x1.5 PG 13.5 DIN
Pneumatic Connections	Supply and Output Pressure: 1/4-18 NPT Gauges: 1/8-27 NPT
Material of Construction	Injected low copper aluminum with polyester painting 316 Stainless Steel housing, with Buna N O-Rings on cover (NEMA 4X, IP66W). Identification Plate: 316 SST.
Mounting	Mounting brackets for linear actuators that comply with IEC 60534-6; and for rotary actuators according VDI/VDE 3845 and NAMUR standards.
Approximate Weights	Without display and mounting bracket: 5.5 kg (316 SST). 2.3 kg (aluminum).

Section 4

LOCAL PROGRAMMING

Local Adjustment

The local adjustment is available for FY500. The interface consists of a liquid crystal display and magnetic tool. The positioner must be powered with at least 9.6V and 3.8 mA to operate the display. Certain procedures require up to 20 mA of current.

Two jumpers are located on the main board to select the local adjustment (W1 jumper) and write protection (W2 jumper).

Before beginning calibration ensure Local Adjustment jumper is in proper position (ON) on the main board. The factory default is (ON) position.

The local adjustment holes are located below the identification plate.

1. To access the local adjustment, loosen the screw and turn the plate to the side.
2. The hole marked with (Z) allows to move forward through the programming tree to the next menu item or increments the currently shown value in the digital display. Holding down the magnetic tool causes the value to increase at a faster rate.
3. The hole marked with (S) allows to select or accept the value or parameter option currently displayed.



WARNING

Do all changes and configurations very carefully since all modifications in the parameters are recorded automatically and do not need user confirmation to save the configuration.

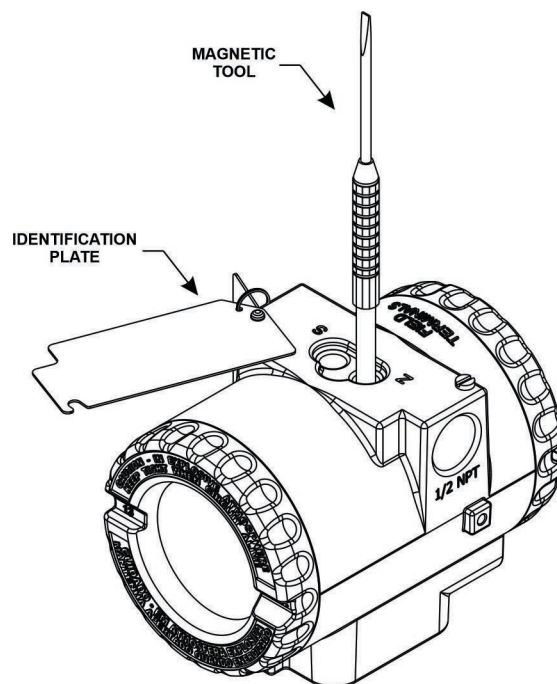

Figure 4.1 – Local Adjustment/Configuration and Magnetic Tool

Jumpers Selection

Two jumpers are located on the main board to select the local adjustment (W1 jumper) and write protection (W2 jumper).

Change the action jumper by setting both jumpers according to Figure 4.2.

Local Adjustment – W1 Jumper

- To select (ON): position the jumper on the **LEFT** side.
- To select (OFF): position the jumper on the **RIGHT** side

Write Protection – W2 Jumper

- To select (ON): position the jumper on the **RIGHT** side.
- To select (OFF): position the jumper on the **LEFT** side.

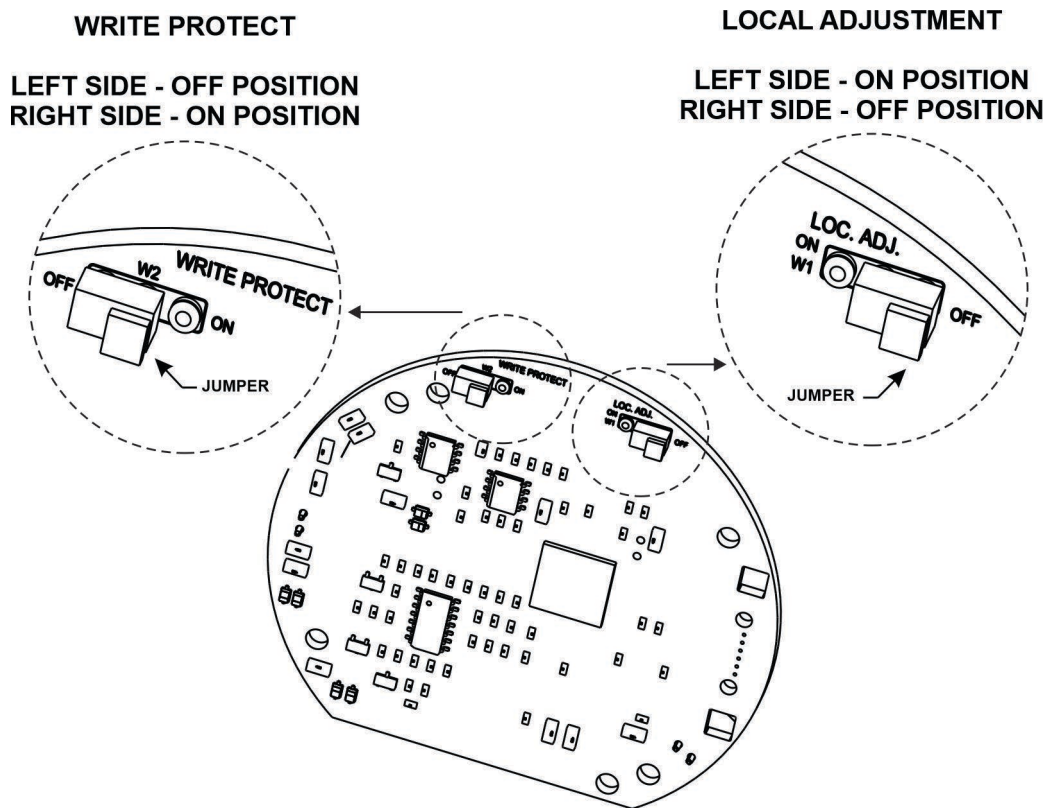

Figure 4.2 – Jumpers on the Main Board

Local Programming Tree

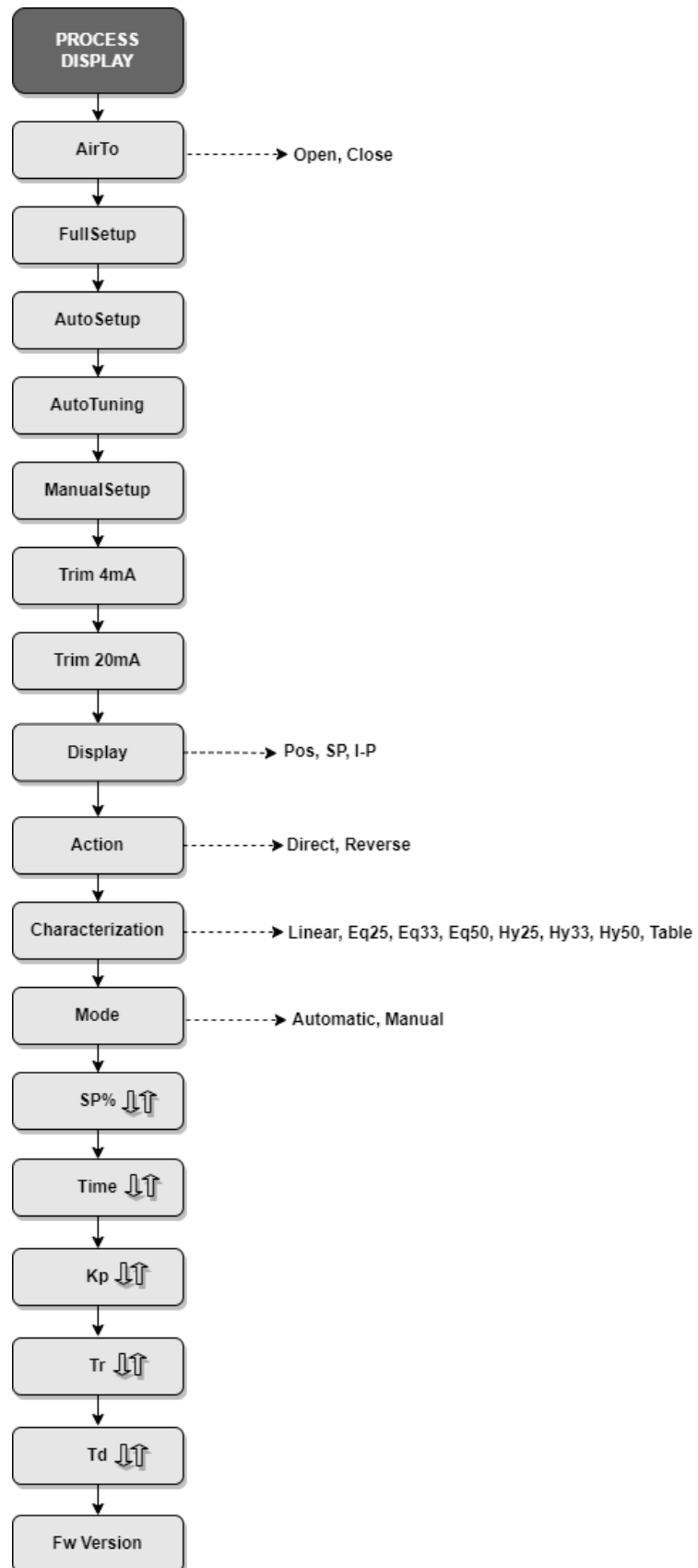

Figure 4.3 – Local Programming Tree

Table 4.1 lists the values that are preconfigured at the factory.

Setup Parameter	Default Setting
AIRTO - Air to Open or Air to Close	Air to Open
ACT – Setpoint action	DIRECT
CHAR - Characterization Curve	LINEAR
MODE - Mode	AUTO
SP % - Set Point	Value read from the process
TIME - Setpoint Variation Time	1 s
Kp - Proportional Gain	3.0
Tr - Integral Time	4.0
Td - Derivative Time	0.5
DISPLAY	PV

Table 4.1 – Factory Default Setting – Local Adjustment

Configurable Parameters



WARNING
Do not touch the moving parts of the valve/positioner/actuator, because they may unexpectedly move automatically.

Below are descriptions of configurable parameters through local adjustment. In parentheses are the ways in which these parameters and their options, if any, appear on the display.

AIRTO (AirTo)

This option allows to adjust the positioner according to the valve actuation. If the actuator works with "air to open" or "air to close", the positioner should be configured for AirTo OPEN(**OP**) or AirTo CLOSE (**CL**), respectively.

FULL SETUP (Full SETUP)

The FULL SETUP procedure will automatically calibrate and adjust the positioner, including valve travel and positioner PID control parameters. Automatic calibration will provide status information as the procedure is running. Typically, the FULL SETUP takes 3 to 5 minutes to tune the positioner, although tuning FY500 mounted on larger actuators may take longer.

AUTO SETUP (Auto SETUP)

Select AUTO SETUP to automatically calibrate the valve travel. The calibration procedure uses the valve/actuator set stops as the 0% and 100% calibration points. Automatic calibration will provide status information as the procedure is running.

AUTOTUNING (tunE SETUP)

The AUTOTUNING procedure will tune the Kp, Tr, and Td values of the internal PID. Automatic calibration will provide status information as the procedure is running.

MANUAL SETUP (man SETUP)

This procedure allows manual calibration of the travel, allowing to determine the 0% and 100% calibration points. It is possible to calibrate the travel less than the physical travel stops allow.

Executes the AUTO SETUP steps but it needs user confirmation between steps.

The user must confirm the current step conclusion only after completely valve stem stops the movement. The steps are described below:

Step 1:

The positioner acts to send the valve/actuator set to the 0% position. Pressure at output 1 goes to its maximum value and output 2 to atmosphere. When the set has stopped at position 0%, the user must place the magnetic tool in (S).

Step 2:

The positioner acts to send the valve/actuator set to the 100% position. Pressure at output 1 goes to its minimum value (atmosphere) and output 2 to maximum. When the set has stopped at 100% position, the user must place the magnetic tool in (S).

Step 3:

After adjusting the position reading gain, the set will be moved to the 0% position again. When the set has stopped at position 0%, the user must place the magnetic tool in (S).

Step 4:

Adjusts the other end of valve travel. No user action required.

NOTES

- The **MANUAL SETUP** is recommended in cases where it is not possible to execute the **AUTO SETUP** procedure due to very unstable environment.
- The display will show messages informing the user of the need for intervention in steps 1, 2 and 3. If the user does not complete the action, the positioner will continue in the current step.

TRIM 4mA (Trim 4mA)

To calibrate the analog input signal, connect a variable current source (4 to 20 mA) to the positioner (+) and (-) terminals. To the follow steps the accuracy of the current source adjustment affects the position accuracy.

1. Adjust the current source to 4 mA (0%)
2. Place the magnetic tool in **S** to confirm. After DONE appears on the display, the trim will be done.

TRIM 20mA (Trim 20mA)

To calibrate the analog input signal, connect a variable current source (4 to 20 mA) to the positioner (+) and (-) terminals. To the follow steps the accuracy of the current source adjustment affects the position accuracy.

1. Adjust the current source to 20 mA (100%).
2. Place the magnetic tool in **S** to confirm. After DONE appears on the display, the trim will be done.

DISPLAY (Disp)

It configures which variable will be shown on the display during the normal operation of the equipment. The options are SP%**(SP)**, PV% **(POS)**, and MV%**(I-P)**.

ACTION (Act)

Direct acting (**di**) - output increases with increasing input signal.

Reverse acting (**re**) - output decreases with increasing input signal.

CHARACTERIZATION - Characterization Curves (Char)

Select desired valve characteristic curve. The custom curve must have been entered through HART Interface.

- **Linear**: linear (**Lin**)
- **(EP25), (EP33), (EP50)**: equal percentage
- **(Hy25), (Hy33), (Hy50)**: hyperbolic (quick opening)
- **(tAb)**: table of 16 points (configurable)

MODE (Mode)

Determines the input mode of the setpoint. There are two modes:

- **AUTOMATIC MODE (Auto)**

The setpoint is determined by the input current.

- **MANUAL MODE (man)**

The setpoint is determined by the user.

SP % - SET POINT (SP)

This parameter represents the desired position value. In the "Manual" mode, this parameter may be changed by user, independently from the input current.

**WARNING**

- When turning the positioner off and on again, it automatically returns to AUTO (Auto Mode).
- When the positioner goes from automatic to manual mode, it keeps the last setpoint value.
- Be careful when the positioner switches from manual to automatic mode, as if the last user-defined setpoint value is too different from the input current, the valve will move abruptly.

TIME - SETPOINT VARIATION TIME (Time)

Determine the time, in seconds, required to move the valve from its fully open position to fully closed, or vice versa based on response parameters measured during the last AUTOTUNING or FULLSETUP procedures. Valid entries are 0 to 120 seconds. The value configured in the local adjustment will be unique and will be the possible opening/closing time.

Kp - PROPORTIONAL GAIN (KP)

Allows to adjust the proportional gain of the internal PID control.

Tr - INTEGRAL TIME (Tr)

Allows to adjust the integral time of the internal PID control.

Td - DERIVATIVE TIME (Td)

Allows to adjust the derivative time of the internal PID control.

FW VERSION (End)

It informs the installed firmware version, for example **V0.07**, and placing the magnetic tool in **S** exits the local adjustment.

Restore Factory Settings

Restoring the calibration returns the calibration parameters to their factory settings. After factory calibration is restored, the positioner must be recalibrated.

To restore the calibration to the factory settings, follow the steps below:

1. Disconnect electric power or a control signal of the positioner.
2. To access the local adjustment, loosen the screw and turn to the indication plate to side.
3. Holding down one magnetic tool on the hole marked with (Z) and other one on the hole marked with (S) simultaneously.
4. With the two magnetic tools in position, apply electric power or a control signal to the positioner.
5. After power on of the input signal, the FY500 initializes for a few seconds. After accomplished start, it factory settings will be restored.

CONFIGURATION VIA HART®

The positioners may be connected in a point-to-point type or multidrop network. In a point-to-point connection, the equipment must be on "0". In a multidrop network, once the devices are recognized by their addresses, the positioners should be configured with a network address between "1" and "15".

If the acknowledgement is via tag, the positioners addresses may be on "0" and keep controlling the valve, even in a multidrop configuration.

NOTE

In case of a multidrop network configuration for classified areas, the entity parameters allowed for the area must be strictly observed. Therefore, the following should be checked:

$$Ca \geq \sum Cj + Cc \quad La \geq \sum Lj + Lc$$
$$Voc \leq \min [Vmax_j] \quad Isc \leq \min [Imax_j]$$

Where:

- Ca, La** = Allowed Capacitance and Inductance on the bus;
- Cj, Lj** = Non -protected internal Capacitance/Inductance of positioner *j* (*j* = up to 15);
- Cc, Lc** = Cable capacitance and Inductance;
- Voc** = open circuit tension of the intrinsic safety barrier
- Isc** = short circuit current of the intrinsic safety barrier
- Vmax_j** = Maximum allowable voltage to be applied to the positioner *j*;
- Imax_j** = Maximum allowable current to be applied to the instrument *j*.

The FY500 Valve Positioner includes a wide variety of HART command functions that makes it possible to access whatever functionality implemented on it. These commands work according to the HART protocol specifications and are grouped as Universal Commands, Common Practice Commands and Specific Commands.

For the user's safety the FY500 has two kinds of write protection in its memory, one hardware and the other a software mechanism. The hardware is selected by a H-H switch with priority over the software (See in the Section 4, Local Programming).

NOTE

The operation and use characteristics of each one of the configurators are in their specific manual. Consult the configurator updates and their respective manuals on <http://www.smar.com> or at their manufacturer.

Configuration Resources

By means of the HART® configurator, the FY500 firmware allows the following configuration features to be accessed; see below:

- Positioner Identification and Manufacturing Data;
- Remote Setpoint;
- Special valve characterization function according to a 16-point configurable curve;
- Flow characterization (Linear, Equal percentage and Quick opening);
- Monitoring of all device variables: position, setpoint, deviation and temperature;
- Positioner diagnostic, preventive maintenance, and failure determination;
- PID controller configuration;
- Device configuration;
- Device maintenance.

The configurator can be connected to the same pair of wires as the 4-20 mA signal, up to 2 kilometers away from the positioner.

Identification and Manufacturing Data

The following information about the **FY500** manufacturing and identification data is available:

TAG

8-character alphanumeric field for identification of the positioner.

DESCRIPTION

16-character alphanumeric field for additional identification of the positioner. May be used to identify service or location.

MESSAGE

32-character alphanumeric field for any other information, such as the name of the person who made the last calibration, some special care to be taken, or if a ladder is needed for physical access to the positioner.

DATE

The date may be used to identify a relevant date, such as the last calibration, the next calibration, or the installation. The date is stored in the American standard e.g.: Oct 16, 2022) and is automatically assumed after the choice of these items.

UNIQUE ID

Used to identify the device and in the construction of the HART long form address.

DEVICE INFORMATION

Allows to read the equipment identification data recorded in the factory.

NOTE

These items related to **EQUIPMENT INFORMATION**, engraved in the factory cannot be modified. They are read directly from the circuit memory.

Monitoring

This function allows remote monitoring of positioner variables. The time to start the reading is around 5 seconds. The values are always updated. Among others, some of the variables that can be monitored are: valve actual position in percentage, input in percentage of the adjusted current range (before the flow limits and linearization), input current in mA or %, device temperature in Celsius and in Fahrenheit degrees, etc.

Device Configuration

NOTE

WRITE PROTECTION – The configurator only shows that the writing is authorized if the **W1 jumper** from main board is connected to the pins over the word **ON** or if the protection is enabled by software.

Besides the equipment configuration and operation services, the **FY500** allows Auto Setup (Calibration) and Auto Tuning. See below the configuration options:

- **CHARACTERIZATION FUNCTION**

This function can change valve flow characteristics. For example, if an equal percentage flow characterization is applied to a valve with linear flow characteristics, it will work as an equal percentage valve. Manufacturer documentation contains the valve inherent characteristic. The options for flow characterization are:

LINEAR	UNALTERED
Equal percentage	1:25
Equal percentage	1:33
Equal percentage	1:50
Quick opening	1:25 (Hyperbolic)
Quick opening	1:33 (Hyperbolic)
Quick opening	1:50 (Hyperbolic)
Table	16 pairs (X, Y)

- **DISPLAY**

The FY500 digital display has three well-defined fields: information field with icons informing the active status of the configuration, 4 ½ numerical digit fields for value indication and alphanumeric field with 5-digit for status information and units. The parameters that can be selected for visualization are showed below:

PARAMETERS	DESCRIPTION
PV %	Process variable in percentage.
SP %	Setpoint in percentage.

- **TABLE CONFIGURATION**

Through this button, a flow characterization curve with up to 16 points can be configured. This allows the construction of a special flow characterization curve, like linear combinations and equal percentage or other characterizations.

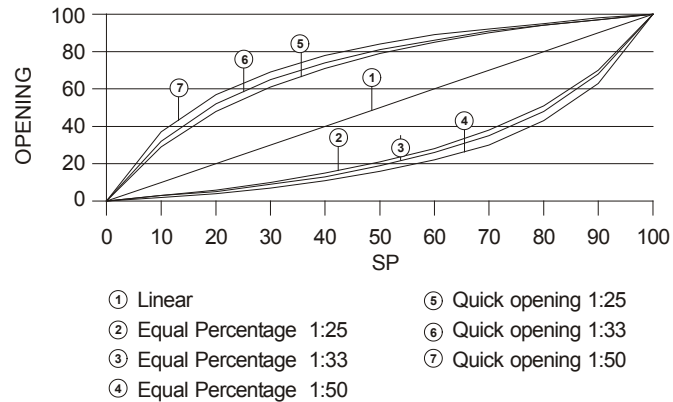

Table 5.1 - Valve Characteristic Curve

Advanced Configuration

This function affects valve advanced configurations. With advanced configuration it is possible to configure the valve type, if it is air-to-open or air-to-close, valve action, setpoint limits and split range.

Device Maintenance

This group includes maintenance services related to obtaining necessary information for the device maintenance and performance test. Some of the available services are: position adjustment and valve performance test, general information about the actuator and the valve, operations count, password level, code number model, performance and others.

Trim

There are two trim operations: current trim and temperature trim which can be performed by standard HART configurators.

- **CURRENT TRIM** allows to check the positioner input current reading. There are two types of current trims available:

4 mA TRIM: is used to adjust the input current reading correspondent to 0%.

20 mA TRIM: is used to adjust the input current reading correspondent to 100%.

- **TEMPERATURE TRIM** is the temperature reference for the positioner temperature sensor.

Automatic Configuration

This function allows to calibrate the valve travel automatically (Auto Setup and Auto Tuning), the points of the totally opened or totally closed stroke with higher precision (lower and higher position), to adjust the opening and closing times and the proportional, integral, and derivative actions of the PID (proportional, integral, derivative) control.

Multidrop Configuration

ADDRESSING

FY500 contains a variable that defines the device address in a HART network. HART addresses assume values from "0" to "15", the addresses "1" to "15" being specific addresses to multidrop connection. When the FY500 is configured for multidrop, it means that the display is showing "MD" and the address is a value from "1" to "15". FY500 is factory-configured with address "0".

Factory

This option is used only in the factory, and the user cannot access it.

Section 6

MAINTENANCE

General Information

NOTE
Equipment installed in hazardous areas must be inspected in compliance with the IEC60079-17 standard.

As a guarantee of quality, the FY500 Valve Positioners are extensively tested and inspected before delivery to the end user. Nevertheless, they were designed to provide an easy periodic cleaning and repair, when necessary.

It is recommended that the end user do not try to repair printed circuit boards. Instead, replace the pieces and, for this, the user should have spare circuit boards, which may be ordered from Smar whenever necessary.

The maintenance procedure is a set of techniques with the purpose of keeping the positioners with higher useful life, to operate in safe conditions and to promote costs reduction. The different types of maintenance are described during this section.

The positioner should be disassembled and undergo cleaning procedures, every time the final element of control is subject to maintenance.

Corrective Maintenance

Unplanned maintenance intends to locate and repair malfunction in the positioners or final elements of control operating in continuous work, or, specifically to suppress already existing defects.

Diagnostics are a set of methods to detect, to locate and eventually to correct errors and problems or even verify failures in the final element of control and in the positioner.

Preventive Maintenance

Planned Maintenance consists of a set of procedures and anticipated actions to keep the device functioning, in other words, mainly to prevent failures, through adjustments, proves and measures according to previously specified values. The preventive maintenance is recommended in the maximum period of one year, or when the process stops.

Diagnostics without HART interface

For a diagnostic without HART interface, perform the following steps.

1. Disconnect the supply pressure. Remove the restriction from I/P Converter Module. Visually check the orifice is clogged. For further information refer to Restriction topic.
2. Disconnect the supply pressure. Connect a 4-20 mA source to the positioner. Rotate the feedback shaft until the valve position reading changes to verify that the Hall sensor position reading is working. For further information refer to Electronic Module topic.
3. Connect the supply pressure to the (IN) port. Cover OUT1 port and OUT2 port with plugs.
 - Without electrical power connected, check if output port (OUT1) is zero and, output port (OUT2) goes to full supply air output. Refer to Transducer Module topic for further information.
 - Connect a 4-20 mA source to the positioner. Turn feedback shaft until cause changes in the outputs pressure. The outputs of a properly calibrated positioner will be in the saturated condition (zero pressure for OUT1 and fully supply for OUT2) or vice versa. Refer to

Transducer Module topic for further information.

To troubleshoot the FY500, refer to Table 6.1.

SYMPTOM	SOURCE / SOLUTION
INITIALIZING MODE – POSITIONER IS NOT POWERING UP	<p>Use a 4 to 20 mA current source to apply power to the positioner Check input signal current. Minimum current for positioner operation is 3.8 mA.</p> <p>Low control system compliance voltage Check system compliance voltage. The voltage drop across the positioner is 9.5VDC while impedance is 475 ohms.</p> <p>Positioner electrical connections Check wiring polarity and continuity.</p> <p>Electronic circuit failure Check the electronic boards for malfunctions and replace them if necessary.</p> <p>Defective terminal block Check continuity from each screw terminal to the corresponding main board connector pin. Replace it if necessary.</p>
VALVE POSITION READING IS NOT WHAT IS EXPECTED	<p>Low control system compliance voltage Check system compliance voltage. The voltage drop across the positioner is 9.5VDC while impedance is 475 ohms.</p> <p>Current leakage Excessive moisture in the terminal block can cause current leakage.</p> <p>Error occurred during calibration Check instrument status on LCD display. Perform calibration.</p>
NO RESPONSE FOR THE INPUT SIGNAL	<p>Air Supply Pressure Low supply pressure.</p> <p>Contamination of the pneumatic module Check the spool valve for contamination (dirty air, oil, dust, etc.).</p> <p>Contamination of the I/P Converter Module Check the nozzle-flapper for contamination.</p> <p>Clogged Restriction Check the orifice for contamination.</p> <p>Error occurred during calibration Check instrument status on LCD display. Perform calibration.</p> <p>Wrong air MODE entered in software Check MODE in manual. Set the MODE to AUTO.</p>
OPERATION INSTABILITY OR POSITIONER OSCILLATION	<p>Feedback arm or rotary adaptor bent/damage Check for excessive play in the linkage and correct.</p> <p>Control tuning parameters are not correct Perform calibration.</p> <p>Contamination of the I/P Converter Module Check the nozzle-flapper for contamination.</p>
POSITION IS DRIVEN FULLY OPEN OR CLOSE AND WILL NOT RESPOND TO COMMAND	<p>Stroke not calibrated Perform calibration.</p> <p>Actuator tubing backward Check air to open/air to close actuator tubing.</p>

Table 6.1 - FY500 - Diagnostics Without Configurator

Diagnostics with HART Interface

For diagnostic with HART interface, perform the following steps.

1. Connect a variable 4-20 mA source to the positioner. Communicates with HART interface.
2. The current signal is the signal to the I/P Converter Module from the analog board. It is the percentage of the microprocessor signal needed to drive the valve fully open. Verify the current signal (40 to 60%) with the valve off the stops. Replace I/P Converter Module if drive signal is continuously high or low. I/P Converter Module may have been adjusted. For further information refer to I/P Converter Module topic.
3. The Hall sensor displays the actual position of the valve. It is absolute number of feedback signal from Hall sensor (0 to 65000). Verify the Hall value (28000 to 37000) with the valve on 50% position (middle travel). If the sensed travel is outside the range of calibrated travel, check the mounting and the travel sensor adjustment. Also, check that the electrical connection from the Hall sensor is properly plugged into the analog board. After restarting the positioner, if the problem does not clear, troubleshooting the Connection Module. For further information refer to I/P Connection Module topic.

Error Messages

The error messages inform which diagnostics were found through errors and malfunctioning self-diagnosis. When the configurator is communicating with the positioner, the user is informed on any problem found, through the self-diagnosis. At the FY500 positioner, the error messages always alternate with the information on the top line of the interface display. The next table lists the error messages and more details on the corrective action.

STATUS	POTENTIAL SOURCE
PARITY ERROR	<ul style="list-style-type: none"> Excessive noise or ripple in the line.
OVERRUN ERROR	<ul style="list-style-type: none"> Low level signal.
CHECK SUM ERROR	<ul style="list-style-type: none"> Damaged interface
FRAMING ERROR	<ul style="list-style-type: none"> Power supply or battery voltage of the configurator lower than 9 V.
BUSY LINE	<ul style="list-style-type: none"> Other device using the line.
CMD NOT IMPLEMENTED	<ul style="list-style-type: none"> Software version not compatible between configurator and positioner.
BUSY DEVICE	<ul style="list-style-type: none"> Positioner carrying out an important task, e.g., local adjustment.
POSITIONER MALFUNCTION	<ul style="list-style-type: none"> Disconnected transducer. Transducer with damage. Stuck valve.
COLD START-UP	<ul style="list-style-type: none"> Start-up or power supply failure.
FIXED OUTPUT	<ul style="list-style-type: none"> Operating in local mode with fixed position.
NO RESPONSE	<ul style="list-style-type: none"> Positioner line resistance is not according to technical characteristics. Positioner without power supply. Interface disconnected or damaged. • When in multidrop mode, check if the positioner is looking for the device at the address where it is configured. Interface damaged. Power supply or battery voltage of the configurator lower than 9 V.

Table 6.2 – FY500 Diagnostics with the Configurator

Electronic Housing Module

The main electronic board contains the circuit board that perform control functions of the positioner. The main board is to be replaced as a unit. None of its components can be repaired.



WARNING

Observe precautions for handling electrostatically sensitive devices.

Removing Electronic Housing Module

To remove the electronic housing module, perform the following steps, refer to figure 6.1.

1. Disconnect electric power and supply pressure from the positioner.
2. Loose the cover locking screw and remove the cover.
3. Being careful not to lose the nylon washer, loosen the two captive main board screws.
4. Pull the main board straight out of the electronic housing. One clear of the housing, swing the main board to the side of the housing to gain access to the cable assemblies.
5. The electronic housing has two cable assemblies, which connect the terminal block to the main board. Disconnect these cable assemblies from the main board.
6. The transducer module has one flat cable, which connect the analog board to the main board. Disconnect this flat cable from the main electronic board.
7. Loose the rotation locking screw.
8. Being careful not to twist the flat cable. Carefully loosen the electronic housing from the transducer module by turning it to unscrew.
9. Remove the electronic housing and inspect the O-ring. Replace it if necessary.

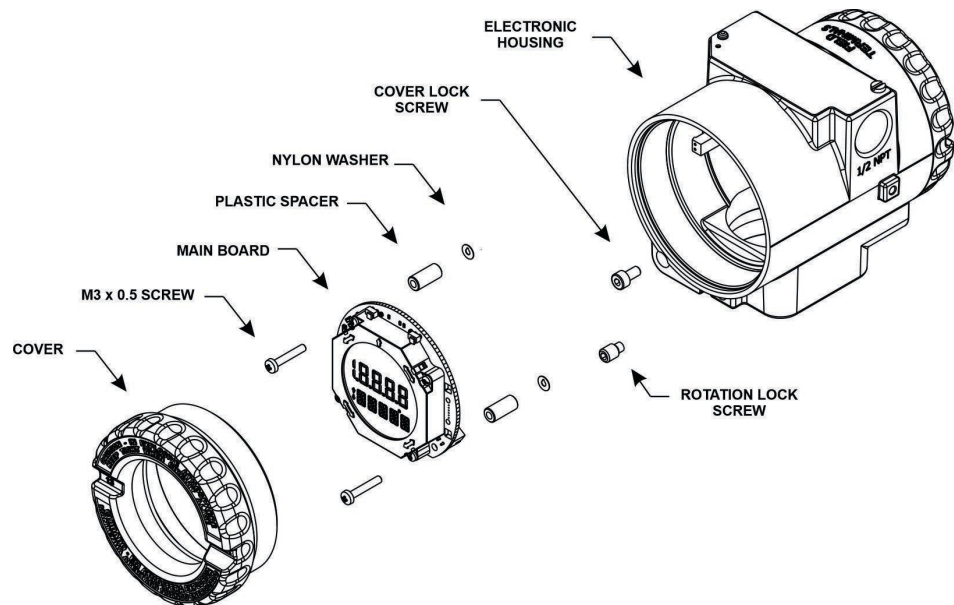

Figure 6.1 – Electronic housing

Replacing Electronic Housing Module

To replace the electronic housing, perform the following steps, refer to **figure 6.1**.

1. Ensure the O-ring is properly installed on the connection module.
2. Being careful not to twist the flat cable. Replace and screw the electronic housing into the transducer module.
3. Tighten the rotation locking screw.
4. Connect the ribbon cable from the transducer module. Orientation of the connector is required.
5. Connect the two cable assemblies to the main electronic board. Orientation of the connectors are required.
6. Replace the main electronic board into the electronic housing. Tighten the two captive screws.

Transducer Module

The transducer module contains the following submodules: **Connection**, **I/P Converter**, **Diaphragm**, **Pneumatic** and **Feedback**. As shown in Figure 6.2.

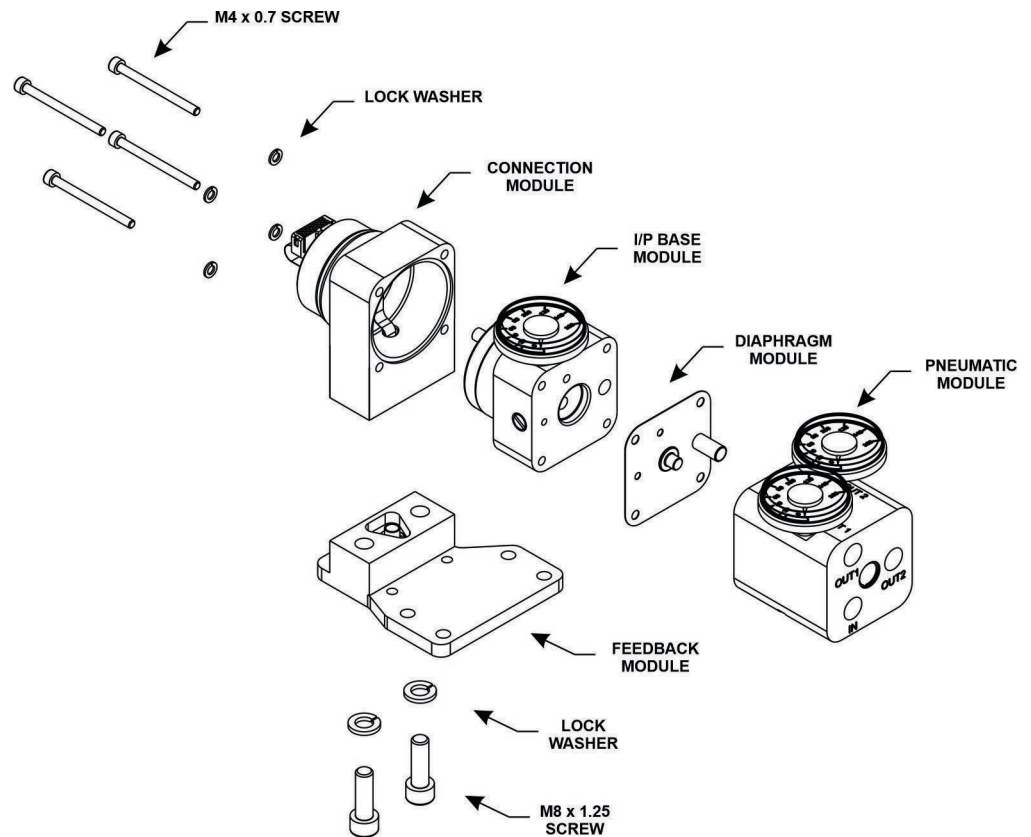

Figure 6.2 – Transducer Module

Connection Module

The Connection Module contains the analog board and the sensor board. The input signal from the main board arrives to the analog board through a flat cable. It is converted to a current signal by the I/P Converter Module. The stem position is sensed through the feedback module by the Hall sensor on the sensor board. The feedback signal from the sensor board is routed into the analog board through a cable assembly.



WARNING

Observe precautions for handling electrostatically sensitive devices.

Removing the Connection Module

To remove the connection module, perform the following steps, refer to figure 6.2.

1. Loosen the four M4 x 0.7 hex head screws.
2. Pull the connection module straight out of the I/P Converter Module. Be careful not to damage the two electrical wires that come out of the I/P Converter Module. Check if the flat cable is not twisted, broken, or oxidized.

Replacing the Connection Module

To replace the Connection Module, perform the following steps, refer to figure 6.2.

1. Install the I/P converter module directly into the connection module, taking care that the two

electrical wires enter the I/P converter guides. These guides route the wires to the analog board.
2. Tighten the four M4 x 0.7 hex head screws.

I/P Converter Module

The I/P Converter Module receives a current signal from analog board and converts it to pneumatic signal to the Diaphragm Module. The analog board determine how much current to send to the coil for a desired pressure signal. The electromagnet field varies the nozzle-flapper spacing, which regulates the I/P output pneumatic signal.

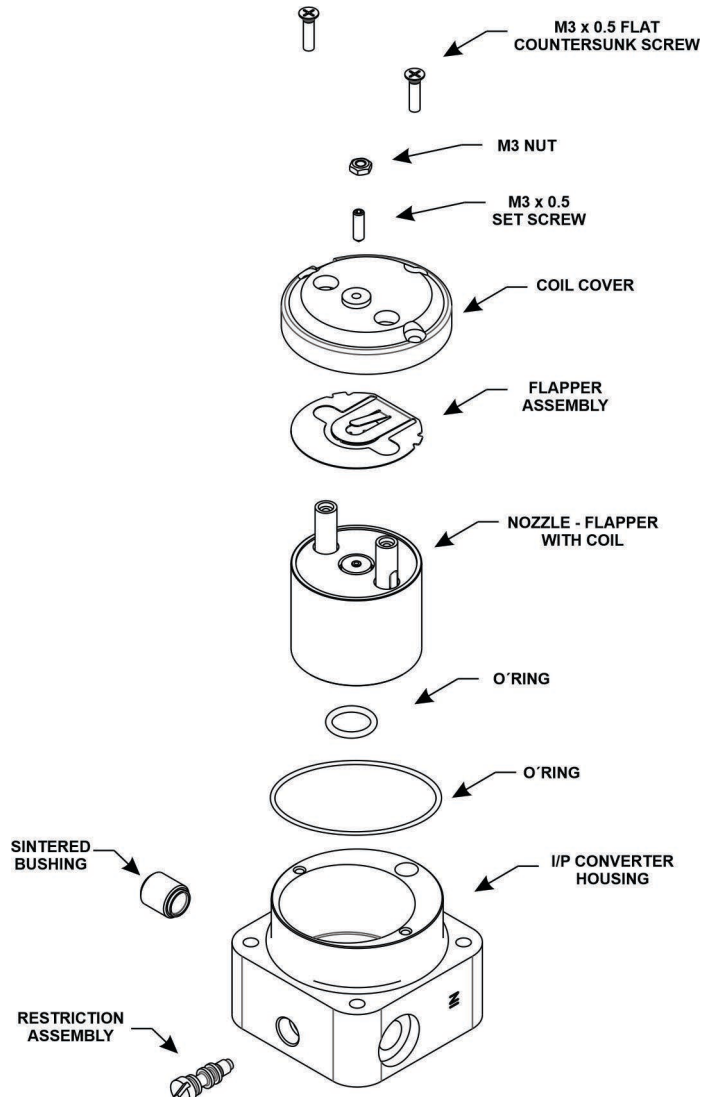

Figure 6.3 – I/P Converter Module (Current/Pressure)

Disassembling Nozzle-Flapper with Coil

To disassemble the Nozzle-Flapper with Coil, perform the following steps, refer to Figure 6.3.

1. Remove the two countersunk head screws (Philips) that attach the coil cover to base.
2. Pull the coil cover straight out of base.
3. Remove the flapper assembly. Check for bent flapper, contamination, or dirty air supply. The flapper can be cleaned with a non-residue cleaner, lint free cloth and soft bristle brush.
4. Remove the nozzle-flapper with coil. Check for open coil (continuity), contamination, or dirty air supply. Coil resistance should be between 1900 to 2100 ohms.

Adjusting Nozzle-Flapper with Coil

To adjust the Nozzle-Flapper with Coil, perform the following steps.

1. Install the I/P Converter Module into the FYCAL base.
2. Install the four screws and evenly tighten.
3. Regulate the supply pressure to the I/P Converter. Regulated pressure should be between 23 to 25 psi.
4. Observe the pressure indicated by the output pressure gauge. The pressure should be between 1.8 to 2.2 psi.
5. To adjust the pneumatic signal, loose the M3 nut and turn the set screw until the pressure indicated on the pressure gauge is 1.8 to 2.2 psi. Tight the nut.
6. Connect the positive wire of the FYCAL to the positive coil receptacle (+) and the negative wire of the FYCAL to the negative coil receptacle (-).
7. Apply 4 mA to the input. Check if the pneumatic signal 15 psi or more.
8. Apply 0 mA to the input. Check if the pneumatic signal is 1.8 to 2.2 psi. The current may affect the adjustment.
9. Repeat steps 5, 6, 7, and 8 until the proper adjustments are obtained.

For more information, refer to the FYCAL manual.

Restriction

The restriction has a small orifice that restricts the flow and air consumption of the air from an internal pressure regulator.

To check the restriction, perform the following steps, refer to figure 6.4.

1. Remove the restriction from the I/P Converter Module.
2. Remove the O-ring with an appropriate tool.
3. Visually verify if the orifice is clogged. If is clogged, dive the part in petroleum base solvent and dry it with dry compressed air (apply the compressed air directly in the smaller orifice for the air to get out through the bigger orifice).
4. Insert the cleaning needle (Code 400-0726) into the restriction hole to prevent any possible obstructions. Take care not to make the orifice larger during cleaning; or positioner performance will be affected.
5. Inspect the O-rings for wear. Replace O-rings.
6. Tightly the Restriction into the I/P Converter Module.

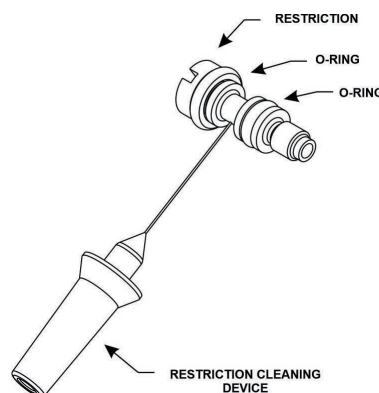

Figure 6.4 – Restriction

Sintered Bushing

The sintered bushing incorporates a filter element in a two-piece bushing. This protects the nozzle-flapper with coil chamber from a moisture and it is exhaust output. To check the sintered bushing, perform the following steps, refer to Figure 6.3.

1. Remove the sintered bushing.
2. Check for contamination or dirty air supply. Replace if necessary.
3. Reinstall the sintered bushing.

Diaphragm Module

The Diaphragm Module receives the signal pressure from nozzle-flapper.

To check the Diaphragm, perform steps, refer to figure 6.2.

1. Remove the Diaphragm Module.
2. Ensure the Diaphragm Module is in good condition. Do not reuse a damage or worn Diaphragm Module. The diaphragm can be cleaned with a non-residue cleaner, lint free cloth and soft bristle brush.
3. When replacing the Diaphragm Module make sure all passages and screw holes are aligned. Place the Diaphragm Module on the I/P Converter Module.

Pneumatic Module

The air passes through an internal pressure regulator that regulates the pressure to approximately 24 psi. The spool valve is also connected to supply pressure and provides two output pressures. The pneumatic signal moves the Diaphragm Module, pushing the spool valve. This opens the spool valve ports.

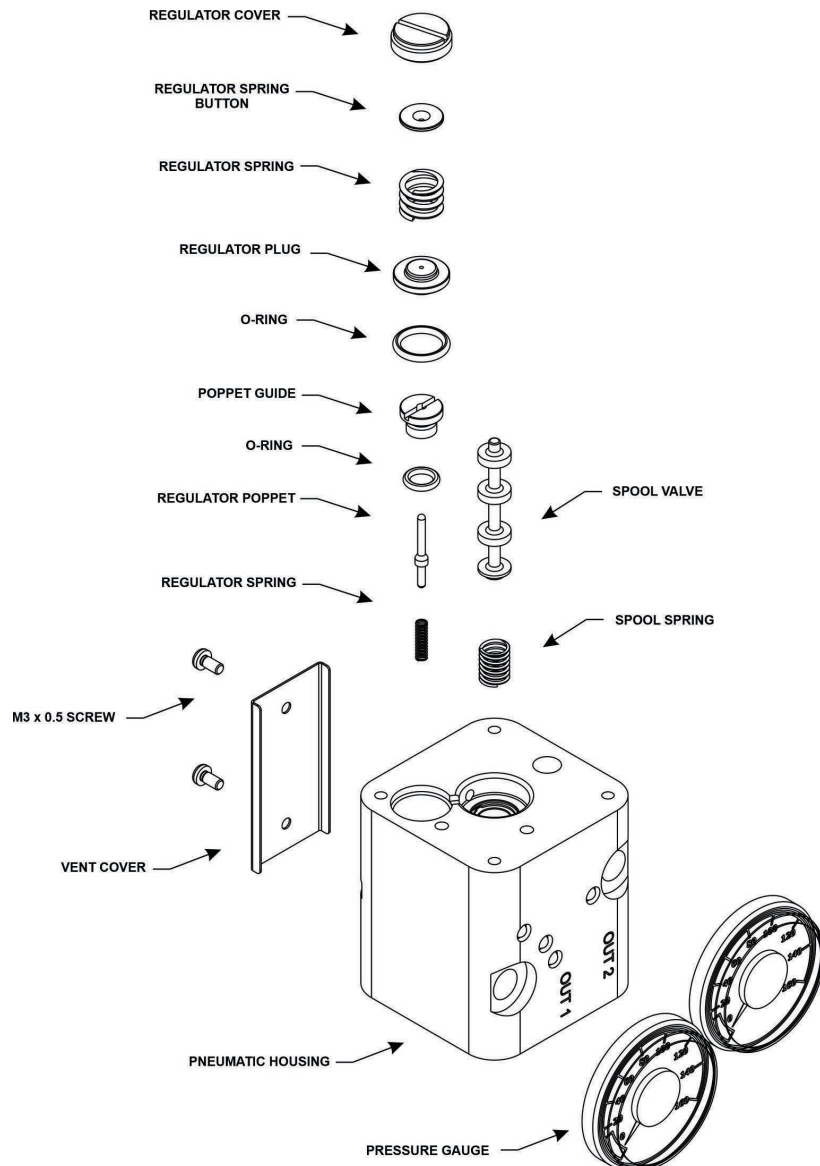

Figure 6.5 – Pneumatic Module

Pressure Regulator

To disassemble the Pressure Regulator, perform the following steps, refer to Figure 6.5.

1. Using a flat screwdriver, remove the regulator cover.
2. Remove the regulator spring button and the regulator spring.
3. Remove the regulator plug and its o-ring.
4. Using a flat screwdriver, remove the poppet guide, its O-ring, the regulator poppet, and the regulator spring.
5. The regulator cavity can be cleaned with a non-residue cleaner, lint free cloth and soft bristle brush.

To assemble the Pressure Regulator, perform the following steps, refer to Figure 6.5.

1. Place the regulator spring and regulator poppet into the housing cavity.
2. Place the poppet guide O-ring on the poppet guide and insert the regulator poppet through the bottom of the poppet guide. Screw the poppet guide into the housing being careful not to over tighten. A maximum torque of 4 to 5 inch-pounds is sufficient. Make sure the poppet is free to move up and down and has spring load.
3. Being careful to push the O-ring into the bore.
4. Place the regulator plug into the bore.
5. Place the regulator spring on the regulator plug, and then place the regulator spring button on the spring.
6. Place a small amount of thread locking compound on the regulator cover and screw into the housing.
7. Position the regulator cover leaving approximately 2 mm of the pneumatic housing surface.

Spool Valve

The spool valve will apportion supply to the actuator. An increase in the loop control signal causes the pneumatic signal increase, pushing the spool and, by means of the pneumatic signal, change the output pressures and flow rate. This will cause the actuator stem movement.



WARNING

Never use oil or lubricant on the spool valve, otherwise the positioner performance will be impaired.

To check the Spool Valve, perform the following steps, refer to Figure 6.5.

1. Remove the spool valve and its spring.
2. Check for scratches, contamination, or dirty air supply. To operate properly, the spool should slide freely and fall through by its own weight when held vertically.
3. The valve spool and the spool cavity can be cleaned with a non-residue cleaner, lint free cloth and soft bristle brush. Blow out all pneumatic connections to prevent dirt, chips, or debris from entering the housing.
4. Place the spool spring and the spool valve into the housing. Do not use any oil or lubricant.

Vent Cover

The Vent Cover incorporates a filter element in a two-piece cover. This protects the spool valve chamber from moisture and provides protection against exhaust air from the spool valve.

To check the Vent Cover, perform the following steps, refer to Figure 6.5.

4. Remove the vent cover.
5. Check for contamination or dirty air supply. Replace it if necessary.
6. Reinstall the vent cover.

Feedback Module

The Feedback Module transmits valve position to analog board. This is accomplished by means of a Hall sensor that connects to the valve stem through a feedback linkage.

To check the Feedback Module, perform the following steps, refer to Figure 6.2.

1. Loosen the two M8 x 1.25 hex head screws. Remove the Feedback Module.
2. Work shaft by hand, make sure that the shaft moves freely. Replace it if necessary.
3. Reinstall the Feedback Module.

Package Content

Verify the package content. The items marked with (*) must be in accordance with the number of positioners supplied.

- Positioner
- Mounting Bracket with Screws (linear or rotary)
- Restriction Cleaning device (*)
- Instructions Manual (*)

Accessories

ACCESSORIES	
ORDERING CODE	DESCRIPTIONS
SD-1	Magnetic tool for configuration via local adjustment.
400-0726	Restriction Cleaning needle.

Exploded View

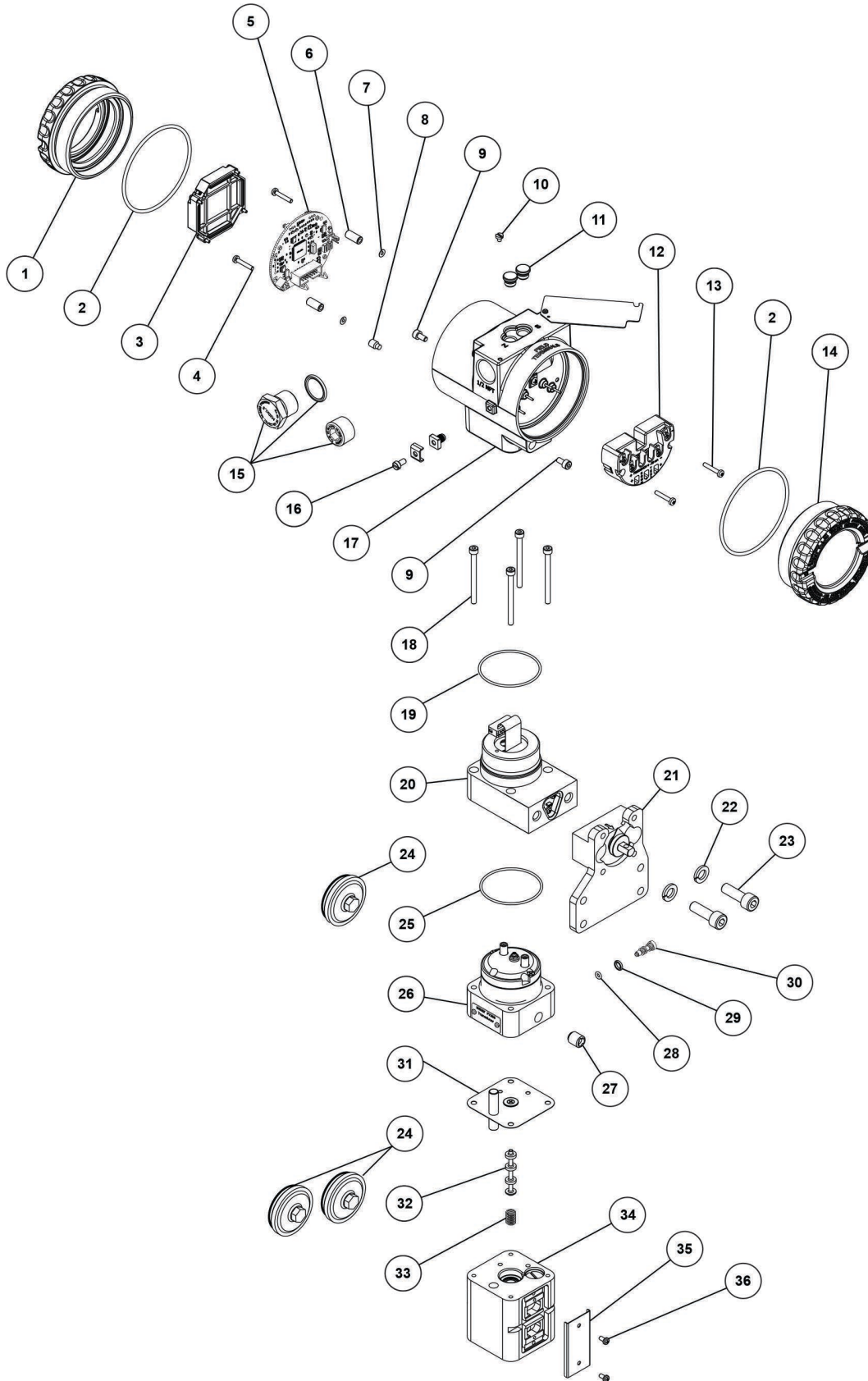

Figure 6.6 – Exploded View

Spare Parts

SPARE PARTS LIST			
PARTS DESCRIPTION	POSITION	CODE	CATEGORY (NOTE 4)
HOUSING (NOTE 1)	17	400-1314-8 (NOTE 6)	-
COVER WITH WINDOW (INCLUDES O-RING)	1	400-0822 (NOTE 6)	-
COVER WITHOUT WINDOW (INCLUDES O-RING)	14	400-1257 (NOTE 6)	-
Cover Locking Bolt	9	204-0120	-
Sensor Locking Bolt (M6 Set Screw)	8	400-1121	-
External Ground Bolt	16	204-0116	-
Identification Plate Fixing Bolt	10	204-0122	-
O-rings Cover (NOTE 2)	2	204-0124	B
Local Adjustment Protection Cover	11	204-0114	-
MAIN ELECTRONIC CIRCUIT BOARD GLL1480 (include digital indicator and mounting kit)	5	400-1511	A
DIGITAL INDICATOR (Display) (include fixing screws)	3	400-1512	A
MOUNTING KIT FOR MAIN ELECTRONIC BOARD (2 bolts with spacers and retention washers)	4, 6, and 7	400-0560	B
TERMINAL INSULATOR FOR 4-20mA POSITION FEEDBACK	12	400-1329	A
TERMINAL BLOCK INSULATOR FIXING SCREW	13	204-0119	
CONNECTION COVER	18, 19, and 20	400-1508 (NOTE 6)	A
. Connection Cover Bolt	18	400-0073	-
. Buna-N Neck O-ring (NOTE 2)	19	204-0113	B
FEEDBACK MODULE	21, 22, and 23	400-1509 (NOTE 6)	A
Two M8 hex head screw and lock washer	21 and 23	400-1519	-
COIL BASE SET	24, 25, 26, 27, 28, 29, and 30	400-1507 (NOTE 6)	A
. Block O-ring (NOTE 2)	26	400-0915	B
. Restriction	30	344-0165	B
. Restriction External O-ring (NOTE 2)	29	344-0155	B
. Restriction Internal O-ring (NOTE 2)	28	344-0150	B
. Sintered Bushing	27	400-0033	B
. Pressure gauge (Stainless Steel and Brass) (NOTE 5)	24	400-1120	B
ASSEMBLED DIAPHRAGM (include hall tube)	31	400-1513	B
PNEUMATIC MODULE	24, 32,33, 34, 35, and 36	400-1505 (NOTE 6)	A
. Pressure gauge (Stainless Steel and Brass) (NOTE 5)	24	400-1120	B
. Spool valve	32	400-1514	B
. Spool valve Spring	33	400-1515	-
. Vent cover - Stainless Steel (included 2 bolts)	35 and 36	400-1516	-
1/2" NPT INTERNAL HEXAGONAL PLUG SST316 BR-Ex-d	15	400-1484 (NOTE 7)	-
M20 X 1.5 (Ex d) HEX HEAD PLUG IN 316 SST	15	400-0810	-
PG13.5 (Ex d) HEX HEAD PLUG IN 316 SST	15	400-0811	-
3/4" NPT (Ex d) ADAPTER IN 316 SST	15	400-0812	-
TRANSDUCER SET	NOTE 3	400-1506 (NOTE 6)	A
VALVE ACTUATOR MOUNTING BRACKET			
Rotary	-	400-1510-1	-
Linear Stroke 12 to 20 mm	-	400-1510-2	-
Linear Stroke 20 to 60 mm	-	400-1510-3	-
Linear Stroke 60 to 120 mm	-	400-1510-4	-
Linear Stroke 120 to 200 mm	-	400-1510-5	-

SPARE PARTS LIST

PARTS DESCRIPTION	POSITION	CODE	CATEGORY (NOTE 4)
POSITIONER MOUNTING BRACKET			
Linear (contains screws and washers (packaged with 12 units))	-	400-1517	-
Rotary (contains screws and washers (packaged with 12 units))	-	400-1518	-

NOTES

- 1) Includes terminal isolator, bolts (cover locking, ground, and terminal isolator) and identification plate without certification.
- 2) O-rings are packaged with 12 units.
- 3) Includes all transducer's spare parts.
- 4) For category **A** it is recommended to keep in stock 25 parts installed for each set and 50 for category **B**.
- 5) The pressure gauges for supply pressure, output 1 or output 2, will be supplied with the wet parts in brass.
- 6) To specify, use the DETAILED CODE FOR ORDERING SPARE PARTS tables. See tables below.
- 7) The spare part 400-1484, Internal Hexagonal Plug 1/2" NPT SST316 BR-Ex-d, was standardized in SST316 material and will be used in all line of housings (aluminum or SST316). With or without certification.

Detailed Code for Ordering Spare Parts

CODE	DESCRIPTION				
400-1314-8	Housing; FY500				
	Option	Communication Protocol			
	H	HART & 4-20 mA			
	Option	Electrical Connection			
	0	½ NPT			
	A	M20 X 1.5			
	B	PG13.5			
	Option	Material			
	H0	Aluminum (IP/Type)			
	H1	Stainless Steel (IP/Type)			
	H2	Aluminum - for saline atmospheres (IPW/Type X)			
	H3	Aluminum Copper Free (IPW/Type X)			
Option	Painting				
P0	Gray Munsell N 6,5				
P8	Without Painting				
400-1314-8	*	*	*	*	TYPICAL ORDERING CODE

CODE	DESCRIPTION				
400-0822	Cover with window; FY500				
	Option	Material			
	H0	Aluminum (IP/Type)			
	H1	Stainless Steel (IP/Type)			
	Option	Painting			
	P0	Gray Munsell N 6,5			
	P8	Without Painting			
400-0822	*	*			TYPICAL ORDERING CODE

CODE	DESCRIPTION				
400-1257	Cover without window; FY500				
	Option	Material			
	H0	Aluminum (IP/Type)			
	H1	Stainless Steel (IP/Type)			
	Option	Painting			
	P0	Gray Munsell N 6,5			
	P8	Without Painting			
400-1257	*	*			TYPICAL ORDERING CODE

CODE	DESCRIPTION			
400-1506	Transducer Set; FY500			
	Option	Indication Gauge		
	0	Without gauge		
	6	01 Gauge - Input		
	7	01 Gauge - Output 1		
	8	02 Gauge - Input and Output 1		
	9	02 Gauge - Output 1 and 2		
	A	03 Gauge		
	Option	Action of Positioner		
	C	Single Action		
	D	Double Action		
	Option	Material		
	H0	Aluminum (IP/Type)		
	H1	Stainless Steel (IP/Type)		
	Option	Painting		
	P0	Gray Munsell N6.5		
	P8	Without Painting		
	Option	Mounting Version		
	R0	Integral Mounting		
400-1506	*	*	*	*

TYPICAL ORDERING CODE

CODE	DESCRIPTION			
400-1505	Pneumatic Module; FY500			
	Option	Indication Gauge		
	0	Without gauge		
	7	01 gauge - Output 1		
	9	02 gauges - Outputs 1 and 2		
	Option	Action of Positioner		
	C	Single Action		
	D	Double Action		
	Option	Material		
	H0	Aluminum (IP/Type)		
	H1	Stainless Steel (IP/Type)		
	Option	Painting		
	P0	Gray Munsell N6.5		
	P8	Without Painting		
400-1505	*	*	*	*

TYPICAL ORDERING CODE

CODE	DESCRIPTION			
400-1507	Coil Base Set; FY500			
	Option	Indication Gauge		
	0	Without Gauge		
	6	01 Gauge - Input		
	Option	Material		
	H0	Aluminum (IP/Type)		
	H1	Stainless Steel (IP/Type)		
	Option	Painting		
	P0	Gray Munsell N6.5		
	P8	Without Painting		
400-1507	*	*	*	

TYPICAL ORDERING CODE

CODE		DESCRIPTION	
400-1508	Connection cover; FY500		
	Option	Material	
	H0	Aluminum (IP/Type)	
	H1	Stainless Steel (IP/Type)	
	Option	Painting	
	P0	Gray Munsell N6.5	
	P8	Without Painting	
400-1508	*	*	TYPICAL ORDERING CODE

CODE		DESCRIPTION	
400-1509	Feedback Module; FY500		
	Option	Material	
	H0	Aluminum (IP/Type)	
	H1	Stainless Steel (IP/Type)	
	Option	Painting	
	P0	Gray Munsell N6.5	
	P8	Without Painting	
400-1509	*	*	TYPICAL ORDERING CODE

Isolation Test on Equipment Housing

1. Power off the equipment in the field, remove its back cover and disconnect all field cables from the transmitter terminal block, isolating them safely.
2. It is not necessary to remove the main board and display.
3. Jumper (connect) the power terminals (positive and negative) with the cable coming from the Megohmmeter (megger).
4. Configure the megohmmeter for 500 Vdc scale and check the isolation between the housing and the cable that short-circuits all the terminals.

ATTENTION	
	Never test with a voltage greater than 500 Vdc.

5. The value obtained must be greater than or equal to 2GΩ and the voltage application time must be at least 1 second and at most 5 seconds.
6. If the value obtained by the megohmmeter is below 2GΩ, the possibility of moisture entering the electrical connection compartment must be analyzed.
7. It is possible to loosen the two screws that secure the terminal block to the housing and carry out a superficial cleaning and dry the surface well. Afterwards, the isolation can be tested again.
8. If the isolation test still shows that the isolation has been compromised, the housing must be replaced and sent to Nova Smar S.A. for analysis and retrieval.

IMPORTANT	
a)	For equipment certified Exd and Exi (Explosion Proof and Intrinsically Safe) the standards advise not to carry out repairs in the field of the housing electronic components, only at Nova Smar S.A.
b)	In normal use, the housing components must not cause failures that affect its isolation. For this reason, it is important to verify whether there are traces of water entering the housing and, if so, an assessment of the electrical installations and the sealing rings of the covers must be carried out. Nova Smar S.A. has a team ready to support the assessment of facilities, if necessary.

CERTIFICATIONS INFORMATION

European Directive Information

Consult www.Smar.com for the EC declarations of conformity and certificates.

Authorized representative/importer located within the Community:

Smar Europe BV De Oude Wereld 116 2408 TM Alphen aan den Rijn Netherlands

ATEX Directive 2014/34/EU - "Equipment for explosive atmospheres"

The EC-Type Examination Certificate is released by DNV Product Assurance AS (NB 2460) and DEKRA Testing and Certification GmbH (NB 0158).

Designated certification body that monitors manufacturing and released QAN (Quality Assurance Notification) is Nemko AS (NB 0470) and UL International Demko AS (NB 0539).

LVD Directive 2014/35/EU – "Low Voltage"

According to the LVD directive Annex II, electrical equipment for use in an explosive atmosphere is outside the scope of this directive.

According to IEC standard: IEC 61010-1 Safety requirements for electrical equipment for measurement, control, and laboratory use - Part 1: General requirements.

PED Directive 2014/68/EU - "Pressure Equipment"

This product is in compliance with Article 4 paragraph 3 of the Pressure Equipment Directive 2014/68/EU and was designed and manufactured in accordance with the sound engineering practice. This equipment cannot bear the CE marking related to PED compliance. However, the product bears the CE marking to indicate compliance with other applicable European Community Directives.

ROHS Directive 2011/65/EU - "Restriction of the use of certain hazardous substances in electrical and electronic equipment"

For the evaluation of the products the following standards were consulted: EN IEC 63000.

EMC Directive 2014/30/EU - "Electromagnetic Compatibility"

For products evaluation, the standard IEC 61326-1 were consulted and to comply with the EMC directive the installation must follow these special conditions:

Use shielded, twisted-pair cable for powering the instrument and signal wiring.

Keep the shield insulated at the instrument side, connecting the other one to the ground.

Hazardous locations general information

Ex Standards:

IEC 60079-0 General Requirements

IEC 60079-1 Flameproof Enclosures "d"

IEC 60079-7 Increased Safe "e"

IEC 60079-11 Intrinsic Safety "i"

IEC 60079-18 Encapsulation "m"

IEC 60079-26 Equipment with Separation Elements or combined Levels of Protection

IEC 60079-31 Equipment dust ignition protection by enclosure "t"

IEC 60529 Classification of degrees of protection provided by enclosures (IP Code)

IEC 60079-10 Classification of Hazardous Areas

IEC 60079-14 Electrical installation design, selection and erection

IEC 60079-17 Electrical Installations, Inspections and Maintenance

IEC 60079-19 Equipment repair, overhaul and reclamation

ISO/IEC 80079-34 Application of quality systems for equipment manufacture

Warning:

Explosions could result in death or serious injury, besides financial damage.

Installation of this instrument in hazardous areas must be in accordance with the local standards and type of protection. Before proceedings with installation make sure that the certificate parameters are in accordance with the classified hazardous area.

Maintenance and Repair

The instrument modification or replaced parts supplied by any other supplier than authorized representative of Smar is prohibited and will void the Certification.

Marking Label

The instrument is marked with type of protection options. The certification is valid only when the type of protection is indicated by the user. Once a particular type of protection is installed, do not reinstall it using any other type of protection.

Intrinsic Safety / Non Incendive application

Only connect the equipment with the "Intrinsic safety" protection type to a circuit intrinsically safe. If the equipment has already been used in circuits not intrinsically safe or if the electrical specifications have not been respected, the safety of the equipment is no longer guaranteed for "Intrinsic Safety" installations.

In hazardous areas with intrinsic safety or non-incendive requirements, the circuit entity parameters and applicable installation procedures must be observed.

The instrument must be connected to a proper intrinsic safety barrier. Check the intrinsically safe parameters involving the barrier and equipment including the cable and connections. Associated apparatus ground bus shall be insulated from panels and mounting enclosures. Shield is optional, when using shielded cable, be sure to insulate the end not grounded.

Cable capacitance and inductance plus C_i and L_i must be smaller than C_o and L_o of the Associated Apparatus.

It is recommended do not remove the housing covers when powered on.

Explosionproof / Flameproof application

Only use Explosionproof/Flameproof certified Plugs, Adapters and Cable glands.

The electrical connections entries must be connected using a conduit with sealed unit or closed using metal cable gland or metal blanking plug with at least IP66.

Do not remove the housing covers when powered on.

Enclosure

The electronic housing and sensor threads installed in hazardous areas must have a minimum of 6 fully engaged threads.

The covers must be tightening with at least 8 turns, to avoid the penetration of humidity or corrosive gases, and until it touches the housing. Then, tighten more 1/3 turn (120°) to guarantee the sealing.

Lock the housing and covers using the locking screw.

The enclosure contains aluminum and is considered to present a potential risk of ignition by impact or friction.

Care must be taken during installation and use to prevent impact or friction.

Degree of Protection of enclosure (IP)

IPx8: Second numeral meaning continuous immersion in water under special condition defined as 10m for a period of 24 hours (Ref: IEC60529).

IPW/ TypeX: Supplementary letter W or X meaning special condition defined as saline environment tested in saturated solution of NaCl 5% w/w at 35°C for a period of 200 hours (Ref: NEMA 250/ IEC60529).

For enclosure with IP/IPW/TypeX applications, all NPT threads must apply a proper water-proof sealant (a non-hardening silicone group sealant is recommended).

Hazardous Locations Approvals

CEPEL

Prova de Explosão (CEPEL 22.2581)

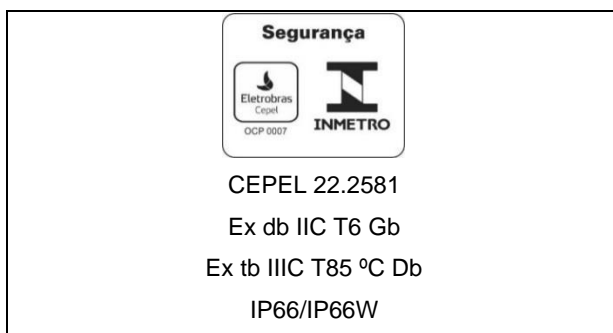

Observações:

- 1) A validade deste Certificado de Conformidade está atrelada à realização das avaliações de manutenção e tratamento de possíveis não conformidades, de acordo com as orientações do Cepel, previstas no Regulamento de Avaliação da Conformidade. Para verificação da condição atualizada de regularidade deste Certificado de Conformidade deve ser consultado o banco de dados de produtos e serviços certificados do Inmetro.
- 2) A tampa do invólucro possui uma plaqueta de advertência com a seguinte inscrição: "ATENÇÃO - NÃO ABRA ENQUANTO ENERGIZADO", ou similar tecnicamente equivalente.
- 3) O produto adicionalmente marcado com a letra suplementar "W" indica que o equipamento foi ensaiado em uma solução saturada a 5% de NaCl p/p, à 35 °C, pelo tempo de 200 h e foi aprovado para uso em atmosferas salinas, condicionado à utilização de acessórios de instalação no mesmo material do equipamento e de bujões de aço inoxidável ASTM-A240, para fechamento das entradas roscadas não utilizadas. Os materiais de fabricação dos equipamentos aprovados para letra "W" são: aço inoxidável AISI 316 e alumínio Copper Free SAE 336 pintados (Procedimento P-CQ-FAB764-11) com tinta Resina Poliéster ou Resina Epóxi com espessura da camada de tinta de 70 a 150 µm e 120 a 200 µm, respectivamente, ou pintados com o plano de pintura P1 e P2 (Procedimento P-CQ-FAB-765-07) com tinta Resina Epóxi ou Poliuretano Acrílico Alifático com espessura de camada de tinta de 290 µm a 405 µm e 90 µm a 200 µm, respectivamente.
- 4) Os planos de pintura P1 são permitidos apenas para equipamento fornecido com plaqueta de identificação com marcação para grupo de gás IIB.
- 5) Este certificado é válido apenas para os produtos dos modelos avaliados. Qualquer modificação nos projetos, bem como a utilização de componentes ou materiais diferentes daqueles definidos pela documentação descritiva dos produtos, sem a prévia autorização do Cepel, invalidará este certificado.
- 6) É responsabilidade do fabricante assegurar que os produtos fornecidos ao mercado nacional estejam de acordo com as especificações e documentação descritiva avaliada, relacionadas neste certificado.
- 7) As atividades de instalação, inspeção, manutenção, reparo, revisão e recuperação dos equipamentos são de responsabilidade dos usuários e devem ser executadas de acordo com os requisitos das normas técnicas vigentes e com as recomendações do fabricante.
- 8) A marcação é executada conforme a Norma ABNT NBR IEC 60079-0:2020 e o Requisito de Avaliação da Conformidade de Equipamentos Elétricos para Atmosferas Explosivas nas Condições de Gases e Vapores Inflamáveis (RAC), e é fixada na superfície externa do equipamento, em local visível. Esta marcação é legível e durável, levando-se em conta possível corrosão química.

Normas Aplicáveis:

ABNT NBR IEC 60079-0:2020 Atmosferas explosivas - Parte 0: Equipamentos – Requisitos gerais

ABNT NBR IEC 60079-1:2016 Atmosferas explosivas - Parte 1: Proteção de equipamento por invólucro à prova de explosão "d"

ABNT NBR IEC 60079-31:2022 Atmosferas explosivas - Parte 31: Proteção de equipamentos contra ignição de poeira por invólucros "t"

ABNT NBR IEC 60529:2017 Graus de proteção providos por invólucros (Código IP)



Desenhos 102A2229, 102A2230, 102A2231



Identification Plate

CEPEL

smar FY500 Posicionador
Nova Smar S/A
Av. Dr. Antônio Furlan Jr
1028 Sertãozinho-SP
14170-480
Brazil



Segurança Ex db IIC T6 Gb CEPEL 22.2581 () **IP 66**



 

 0000000 - 0000 **HART**  **CE** **222900**

smar FY500 Posicionador
Nova Smar S/A
Av. Dr. Antônio Furlan Jr
1028 Sertãozinho-SP
14170-480
Brazil



Segurança Ex db IIC T6 Gb CEPEL 22.2581 () **IP 66W**



 

 0000000 - 0000 **HART**  **CE** **223000**

smar FY500 Posicionador
Nova Smar S/A
Av. Dr. Antônio Furlan Jr
1028 Sertãozinho-SP
14170-480
Brazil

Segurança Ex tb IIIC T85°C Db CEPEL 22.2581 () **IP 66**

 0000000 - 0000 **HART**  **CE** **223100**